



No. 4 1977

issued quarterly

Technical Review

To Advance Techniques in Acoustical, Electrical and Mechanical Measurement

Accuracy of Sound Level Meters

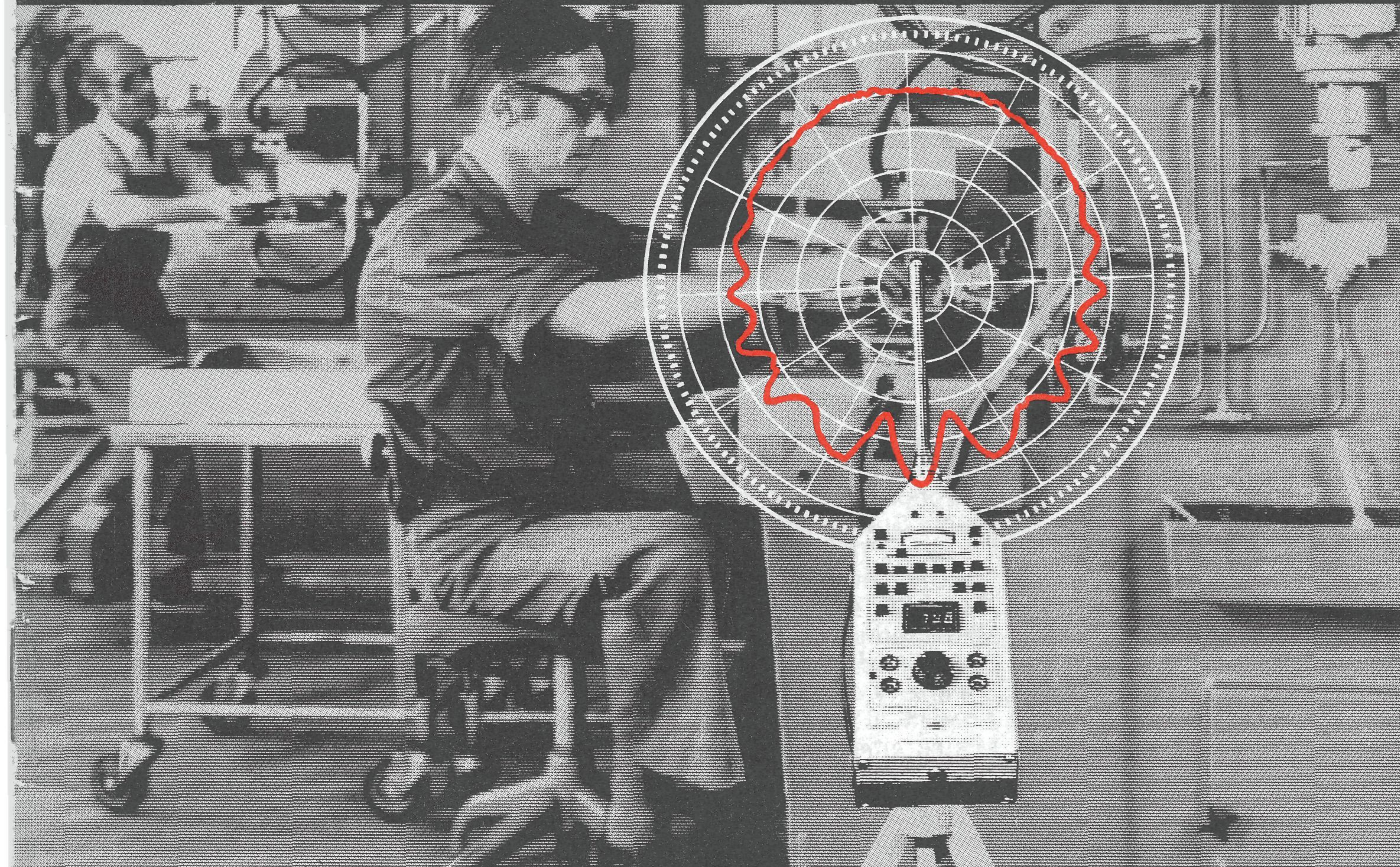

Low Impedance Microphone Calibrator

Brüel & Kjær

**PREVIOUSLY ISSUED NUMBERS OF
BRÜEL & KJÆR TECHNICAL REVIEW**

- 3-1977 Condenser Microphones used as Sound Sources.
2-1977 Automated Measurements of Reverberation Time using the Digital Frequency Analyzer Type 2131.
Measurement of Elastic Modulus and Loss Factor of PVC at High Frequencies.
1-1977 Digital Filters in Acoustic Analysis Systems.
An Objective Comparison of Analog and Digital Methods of Real-Time Frequency Analysis.
4-1976 An Easy and Accurate Method of Sound Power Measurements.
Measurement of Sound Absorption of rooms using a Reference Sound Source.
3-1976 Registration of Voice Quality.
Acoustic Response Measurements and Standards for Motion-Picture Theatres.
2-1976 Free-Field Response of Sound Level Meters.
High Frequency Testing of Gramophone Cartridges using an Accelerometer.
1-1976 Do We Measure Damaging Noise Correctly?
4-1975 On the Measurement of Frequency Response Functions.
3-1975 On the Averaging Time of RMS Measurements (continuation).
2-1975 On the Averaging Time of RMS Measurements
Averaging Time of Level Recorder Type 2306 and "Fast" and "Slow" Response of Level Recorders 2305/06/07
1-1975 Problems in Telephone Measurements.
Proposals for the Measurement of Loudness Ratings of Operators' Headsets.
Comparison of Results obtained by Subjective Measuring Methods.
Repeatabilities in Electro-Acoustic Measurements on Telephone Capsules.
Stable Subset Measurements with the 73 D
Vibration Testing of Telephone Equipment.
4-1974 Underwater Impulse Measurements.
A Comparison of ISO and OSHA Noise Dose Measurements.
Sound Radiation from Loudspeaker System with the Symmetry of the Platonic Solids.
3-1974 Acoustical Investigation of an Impact Drill.
Measurement of the Dynamic Mass of the Hand-arm System.

(Continued on cover page 3)

TECHNICAL REVIEW

No. 4 — 1977

Contents

| | |
|--|----|
| General Accuracy of Sound Level Meter Measurements by P. Hedegaard | 3 |
| Low Impedance Microphone Calibrator and its Advantages by E. Frederiksen | 18 |
| News from the Factory | 26 |

General Accuracy of Sound Level Meter Measurements

by

P. Hedegaard

ABSTRACT

From the tolerance levels given in IEC standards for sound level meters it can be seen that at medium high and high frequencies very large deviations may occur between results obtained from different sound level meters fulfilling the same standard. This is partly due to the wide tolerances on frequency response and directional sensitivity characteristics and partly due to the use of different microphone features such as flat 0° incidence free-field response or flat random incidence frequency response. The poorly defined impulse response requirements for "Fast" and "Slow" detector/indicator modes may also result in appreciable deviations in the results, when measuring impulsive noise.

In this article the theoretical deviations between measurements with different microphone sizes and configurations are compared to the deviations found in practical measuring situations. The deviations in measured results due to different detector/indicator systems are also discussed.

SOMMAIRE

A partir des niveaux de tolérance donnés dans les normes CEI pour les sonomètres, on peut remarquer qu'au niveau des fréquences moyennement hautes et des hautes fréquences de très larges déviations peuvent avoir lieu entre les résultats obtenus à la même norme. Cela est partiellement dû d'une part aux larges tolérances sur la réponse en fréquence et les caractéristiques de sensibilité directionnelle et d'autre part à l'utilisation de caractéristiques de microphone différentes telle qu'une réponse plate en champ libre sous incidence 0° ou bien une réponse plate sous incidence aléatoire.

Les exigences de réponse aux impulsions insuffisamment bien définies pour les modes "Fast" (Rapide) et "Slow" (Lent) des détecteurs/indicateurs peuvent également résulter en d'appréciables déviations dans les résultats dans le cas des mesures de bruits impulsifs.

Dans cet article, les déviations théoriques entre les mesures avec différentes configurations et différentes tailles de microphone sont comparées aux déviations obtenues au cours de mesures pratiques. L'article traite également des déviations dans les résultats de mesure dues aux différents systèmes détecteur/indicateur.

ZUSAMMENFASSUNG

Aus den IEC-Standards für Schallpegelmesser ist ersichtlich, daß bei mittelhohen und hohen Frequenzen sehr große Abweichungen zwischen den Ergebnissen von verschiedenen Schallpegelmessern, die die selbe Norm erfüllen, entstehen können. Dieses entsteht zum Teil durch große Toleranzen im Frequenzgang und der Richtcharakteristik und zum Teil durch verschiedene Mikrofoneigenschaften, wie Freifeld- und Diffusfrequenzgang. Das für die Anzeigearten "Schnell" ("Fast") und "Langsam" ("Slow") dürftig definierte Reagieren auf Impulse kann ebenso merkliche Abweichungen der Ergebnisse zur Folge haben, wenn impulsartige Geräusche gemessen werden.

In diesem Artikel werden die theoretischen Abweichungen von Messungen mit Mikrofonen verschiedener Gestalt und Größe mit den tatsächlich erhaltenen Abweichungen verglichen. Ebenso werden die Abweichungen durch verschiedene Anzeige- und Meßsysteme diskutiert.

Introduction

The accuracy of a sound level measurement depends not only on the accuracy of the measuring system but also on how the instrumentation is used. The user's knowledge of the correct method of reading the instrument, the proper placing of the acoustical transducer or microphone in the sound field that is to be described, and a good understanding of the uncertainties, especially in cases where sound interference occurs, are important factors which determine the reliability of the results.

The precision of the instrumentation depends on its electrical and acoustical performance and on the absolute calibration in some reference condition. Accuracy of the absolute sensitivity in a reference condition (frequency, sound pressure level) will depend on the calibration equipment and on the stability of the measuring instrumentation during the period between calibrations. Various precision methods are available for this purpose.

The acoustical performance of the instrument is dependent partly on the precision of the microphone and its mechanical connection to the body of the instrument (normally a sound level meter). While the shape of the mechanical fixture or the connected apparatus may influence the measurements, dependent on the bandwidth of the sound to be measured, the performance of the microphone itself is important in nearly every case.

Although the free-field frequency response of the microphone in a specific direction can be electrically corrected, the same cannot be done for the directional characteristics. Mechanical corrections may be made, but a real improvement is only possible by reduction of the size

of the microphone. Existing and forthcoming sound level meter standards are in principle based on pure omnidirectivity of the microphone, i.e. equal sensitivity for all directions of sound incidence. The tolerances are then set so that microphones of a certain size can fulfil the requirements. These tolerances, however, are rather wide as they must include **both** the ideal omnidirectional microphone as well as practical available measuring microphones, see Fig.1.

In cases where the sound arrives from a specific direction no problems are encountered, but in a diffuse sound field, microphones of different sizes, even though they may be approximately equal in frequency response for a specific direction of incidence of the sound, will be different in sensitivity. As different national standards are based either on free-field frequency response in the direction of the microphone that is most sensitive, i.e. the direction perpendicular to the diaphragm, or on a diffuse or random-field frequency response, it is obvious that an error may easily be introduced if measured results are compared. This is one of the weak points in the standards and will therefore be discussed in some detail.

The electrical performance of the instrumentation that does not rely only on the microphone characteristics, may be split up into three parts.

1. The frequency weighting
2. The amplitude linearity
3. The performance of the detector/indicator system.

The requirements for the frequency weighting are combined with the free-field response of the microphone in a reference direction or mode. As the microphone response in most cases is rather well defined with respect to this, the electrical performance will seldom give rise to significant inaccuracies.

The amplitude linearity which describes the error in the measured level with respect to a ref. level, and the differential amplitude linearity which describes the error in a measured level difference are well-defined requirements for the instrumentation, and tolerances seem to be well matched to other tolerance requirements. The amplitude linearity tolerances take into consideration the sum of the tolerances on the level range control and on the meter scale accuracy. The differential amplitude linearity tolerances may be understood as the tolerances on a meter scale accuracy.

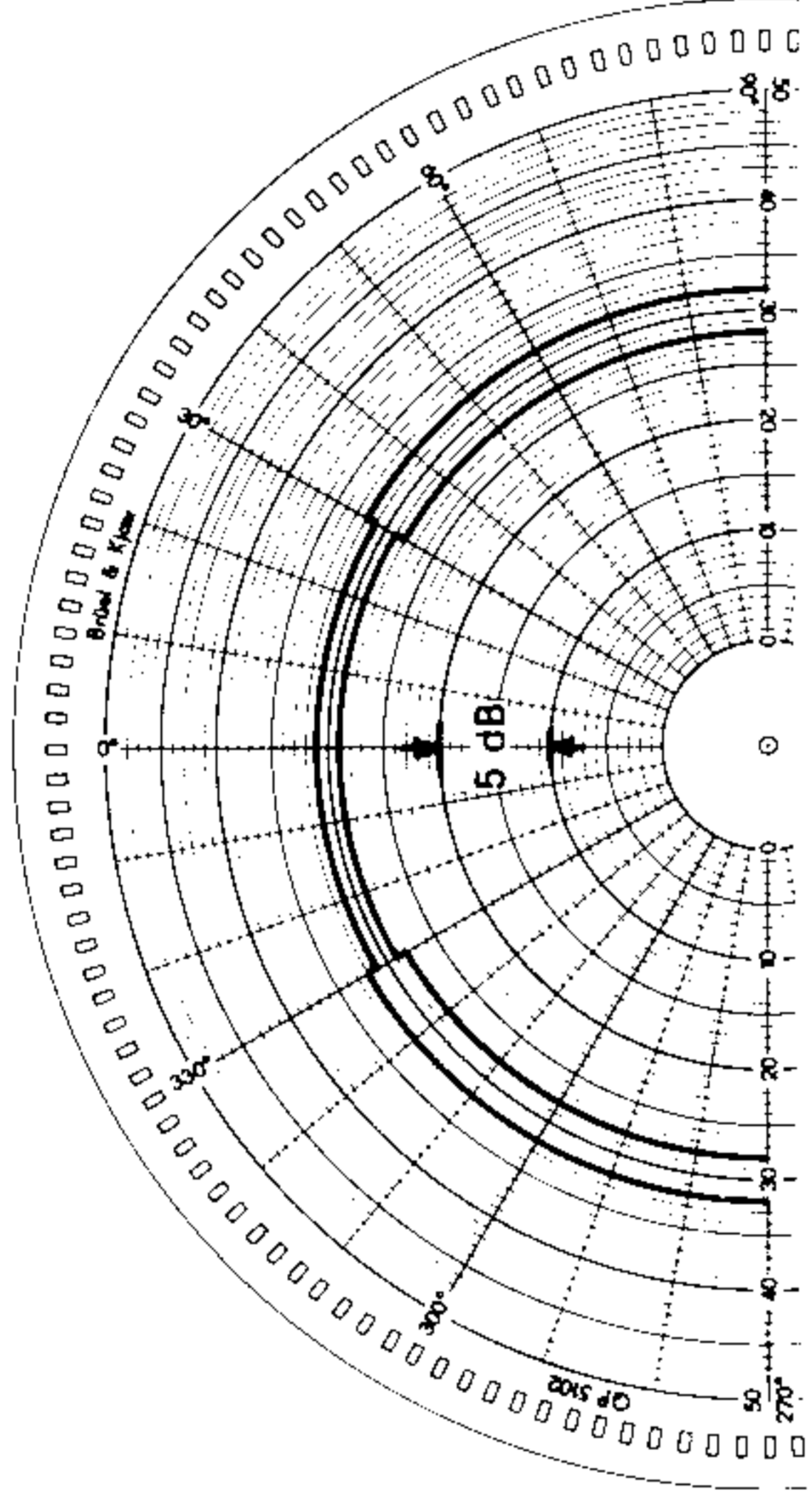
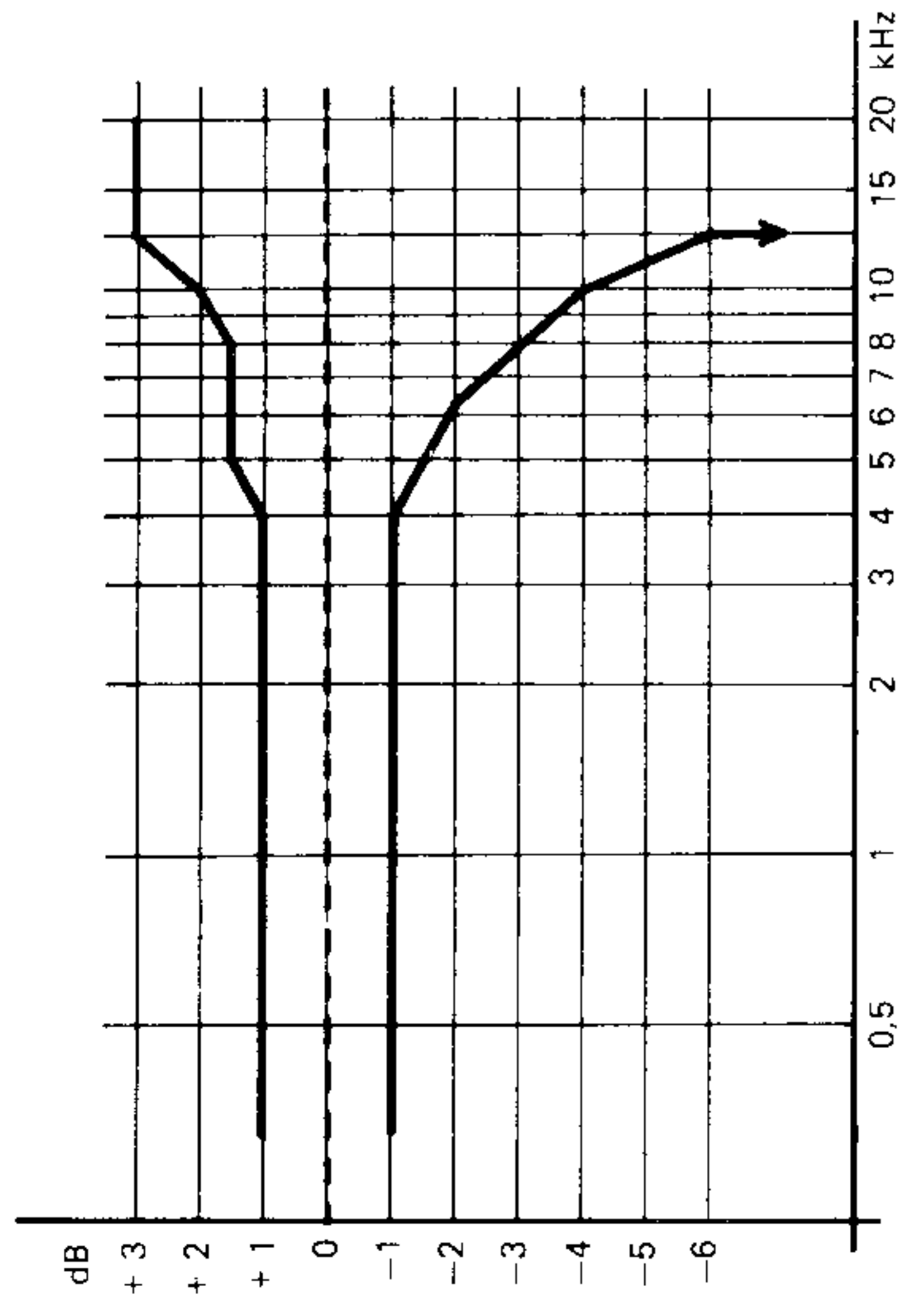

31,5 Hz — 1 kHz

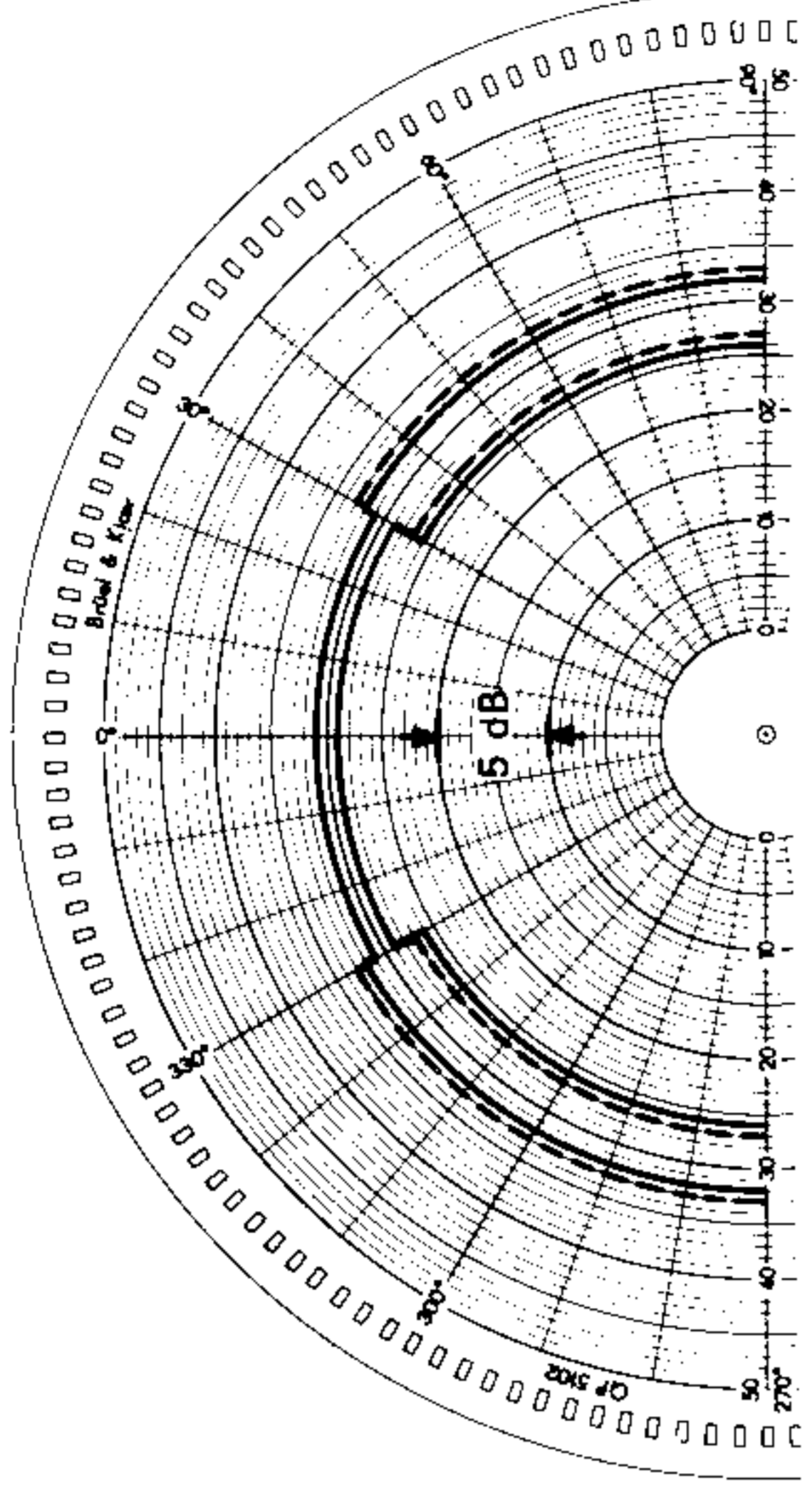

1 kHz — 2 kHz

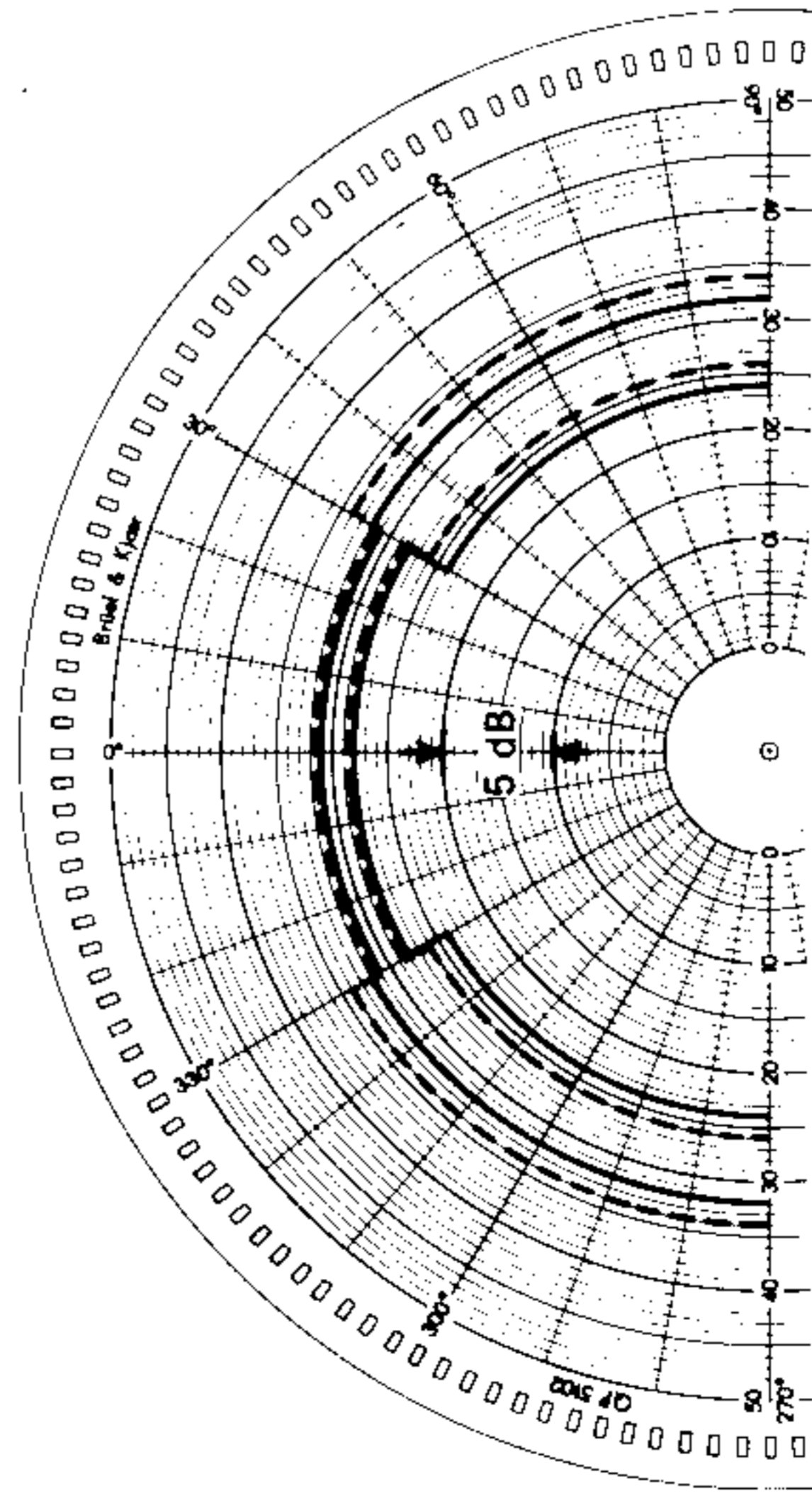

2 kHz — 4 kHz

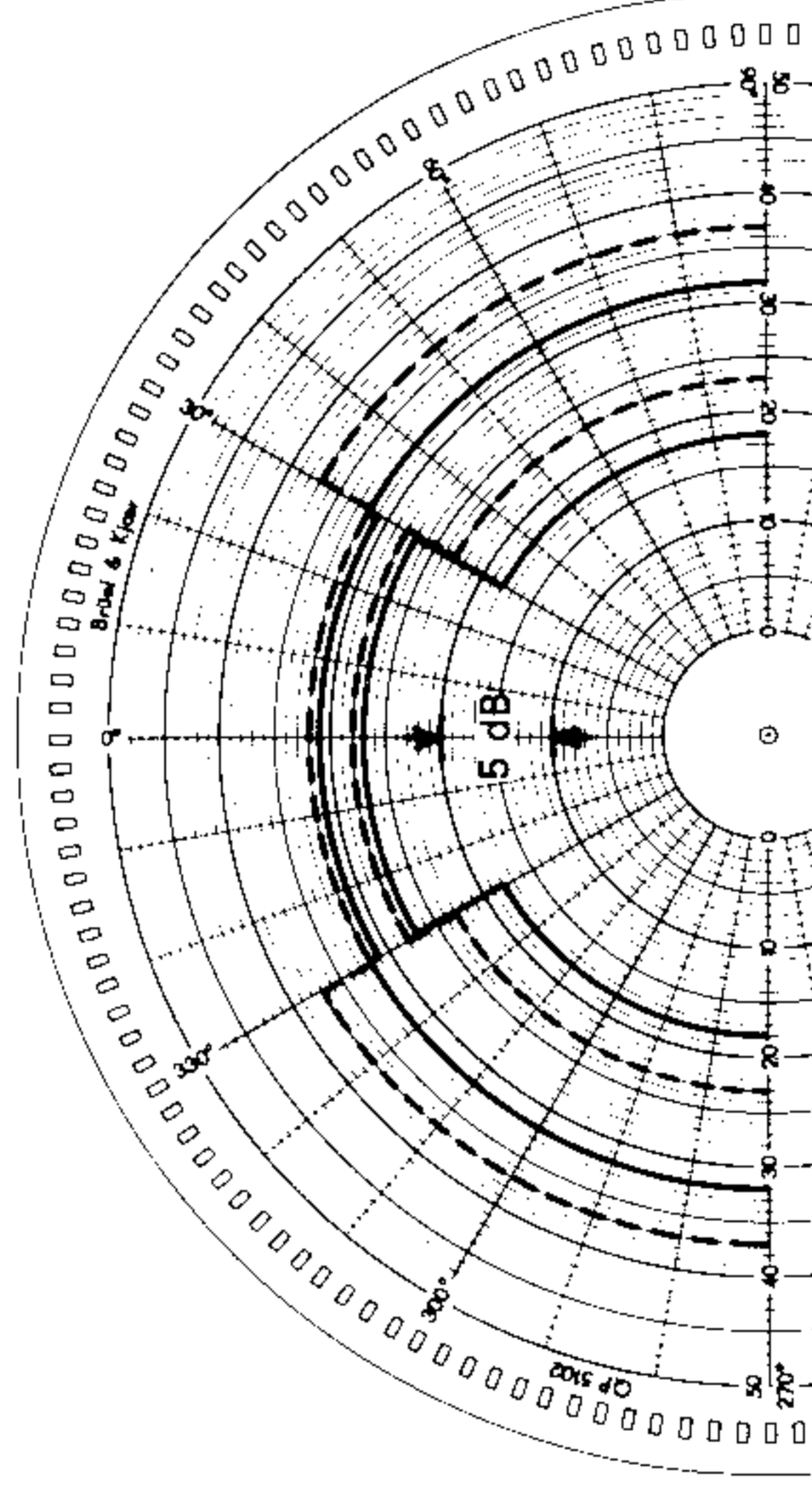

4 kHz — 8 kHz

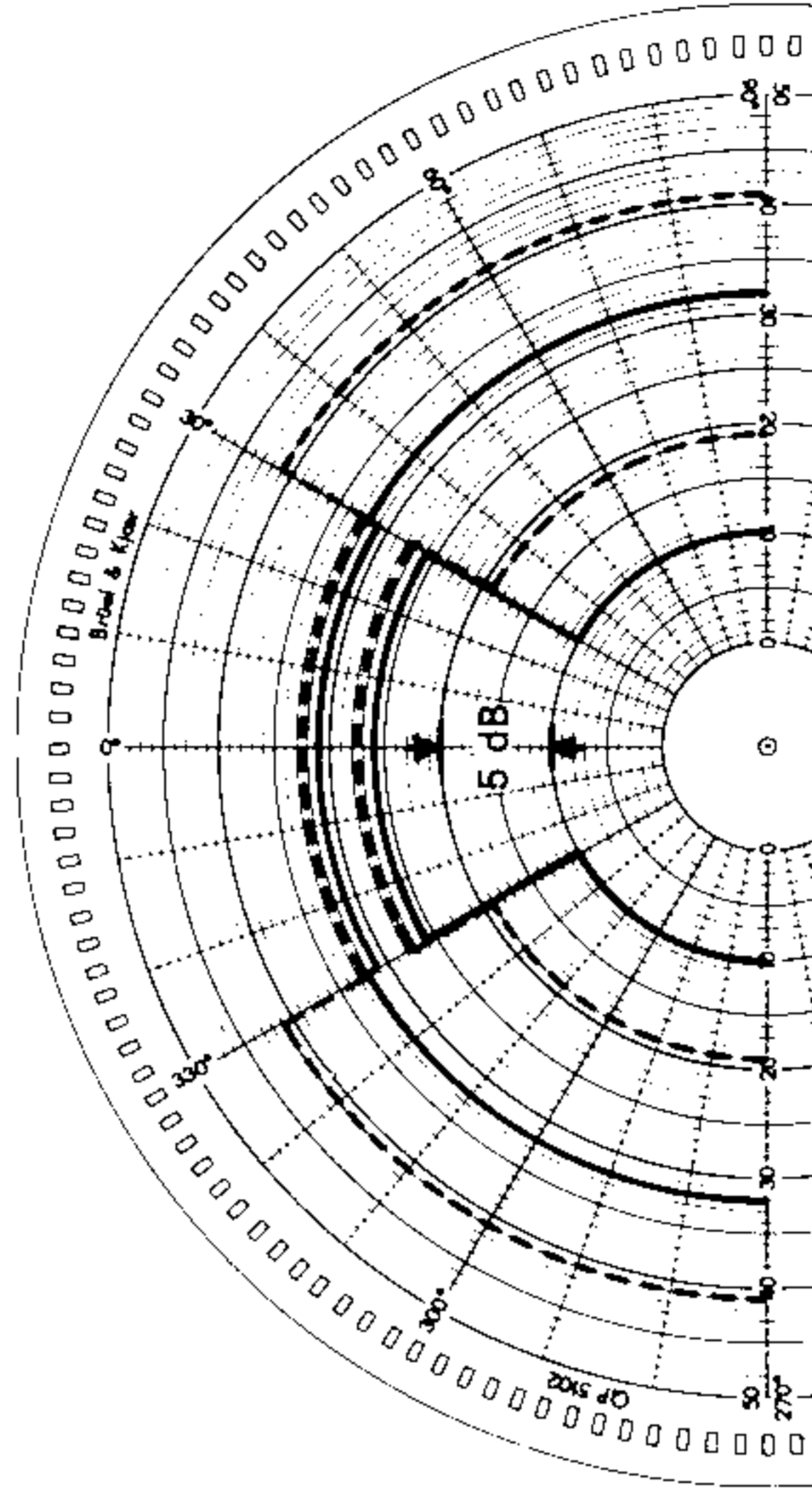

8 kHz — 12,5 kHz 760074

Fig.1. IEC 179 Tolerances for frequency response and directional sensitivity

The performance of the detector-indicator system depends on:

1. The detector's ability to give the correct RMS response to signals with varying crest factor, 2. The dynamics of the indicator.

The detector's ability to respond correctly to signals with high crest factors, is important, especially for the "Slow" mode, where the time constant of the detector is large (to keep the fluctuations of the indicator system to a low value) and for the "Impulse" mode where the indicator response is well defined.

If large fluctuations in the detector/indicator response occur for the "Fast" or "Slow" modes, problems concerning the dynamic behaviour of the indicator system become significant. The same applies if single impulses are measured in these modes.

In existing standards for precision and general-purpose sound level meters, the dynamic response requirements for each of the detector-indicator modes, "Fast" and "Slow", are only defined by the response to one single tone burst and by a requirement for some overshoot when a steady signal of constant amplitude is applied. As the response to fluctuating signals depends on the impulse response, it is seen that as soon as signals fluctuate, (as they very often do in practice) the response will be more or less undefined. This is another point of weakness in the standards and its consequences will be discussed.

Consequences of different directional sensitivity responses

In Fig.2, the upper graph shows the tolerances laid down by IEC for Precision Sound Level Meters.

For the sake of comparison, the middle graph shows the free-field frequency response of some microphones for sound incidence in their reference direction. the Microphone sizes are 1/4" to 1". One microphone is a random or diffuse-field type placed with the sound impinging on the diaphragm at grazing incidence. Note that even though the microphones vary in size by a factor of 4 and one is a "random" type, their free-field responses differ very little for frequencies below 10 kHz.

The sensitivity in a diffuse sound field, on the contrary will differ much more because of the different directional characteristics of the microphones. The use of a random type microphone (Type 4166) will increase the spread further as can be seen from the bottom graph.

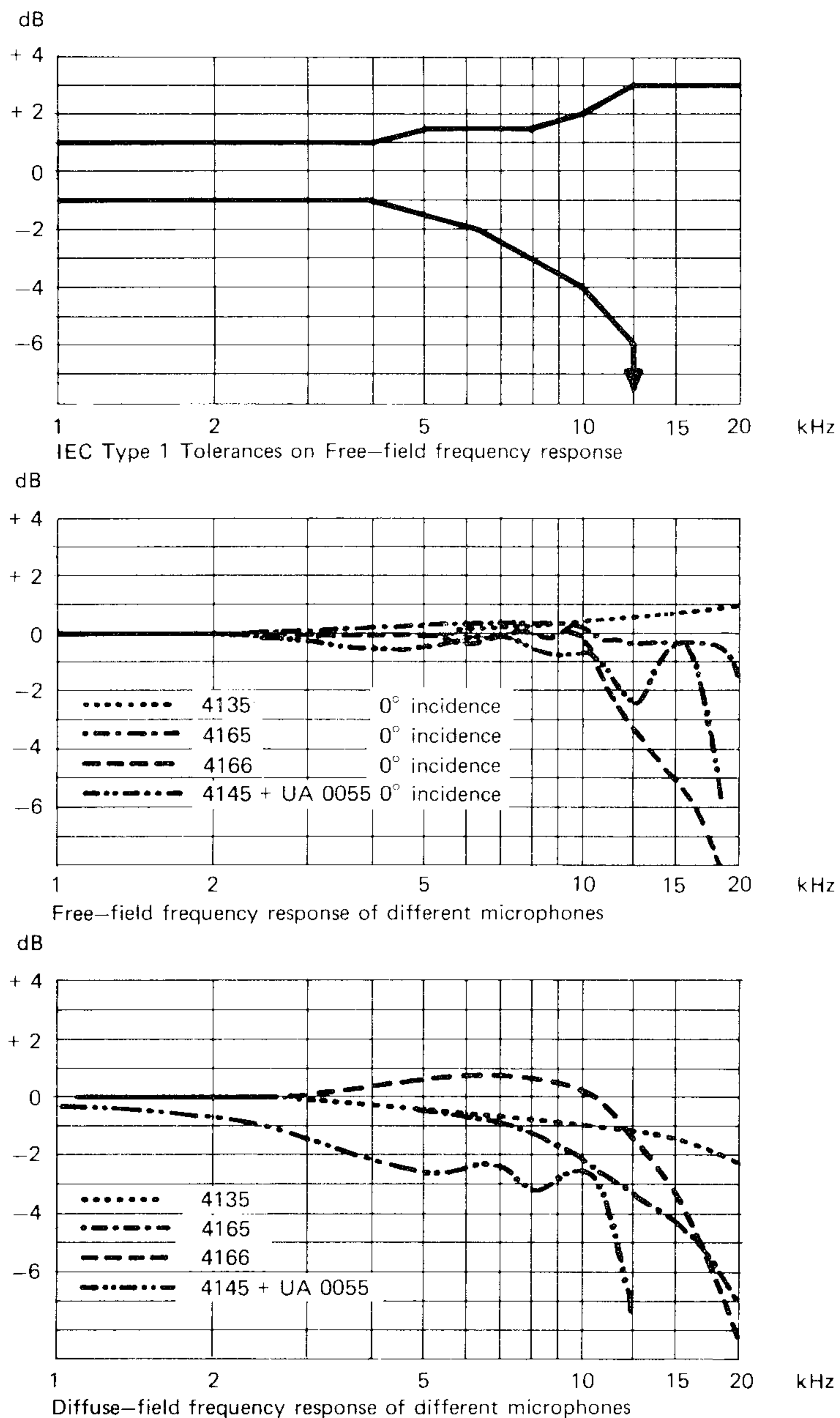

770618

Fig.2. Comparison between IEC Type 1 Tolerances for free-field frequency response and the free-field response of microphones of different sizes

The spread in the graphs of Fig.2 are plotted in Fig.3. Note that the spread for the diffuse-field response (bottom graph) is *not* to be compared directly with the permissible spread for the free-field characteristics but is an additional uncertainty.

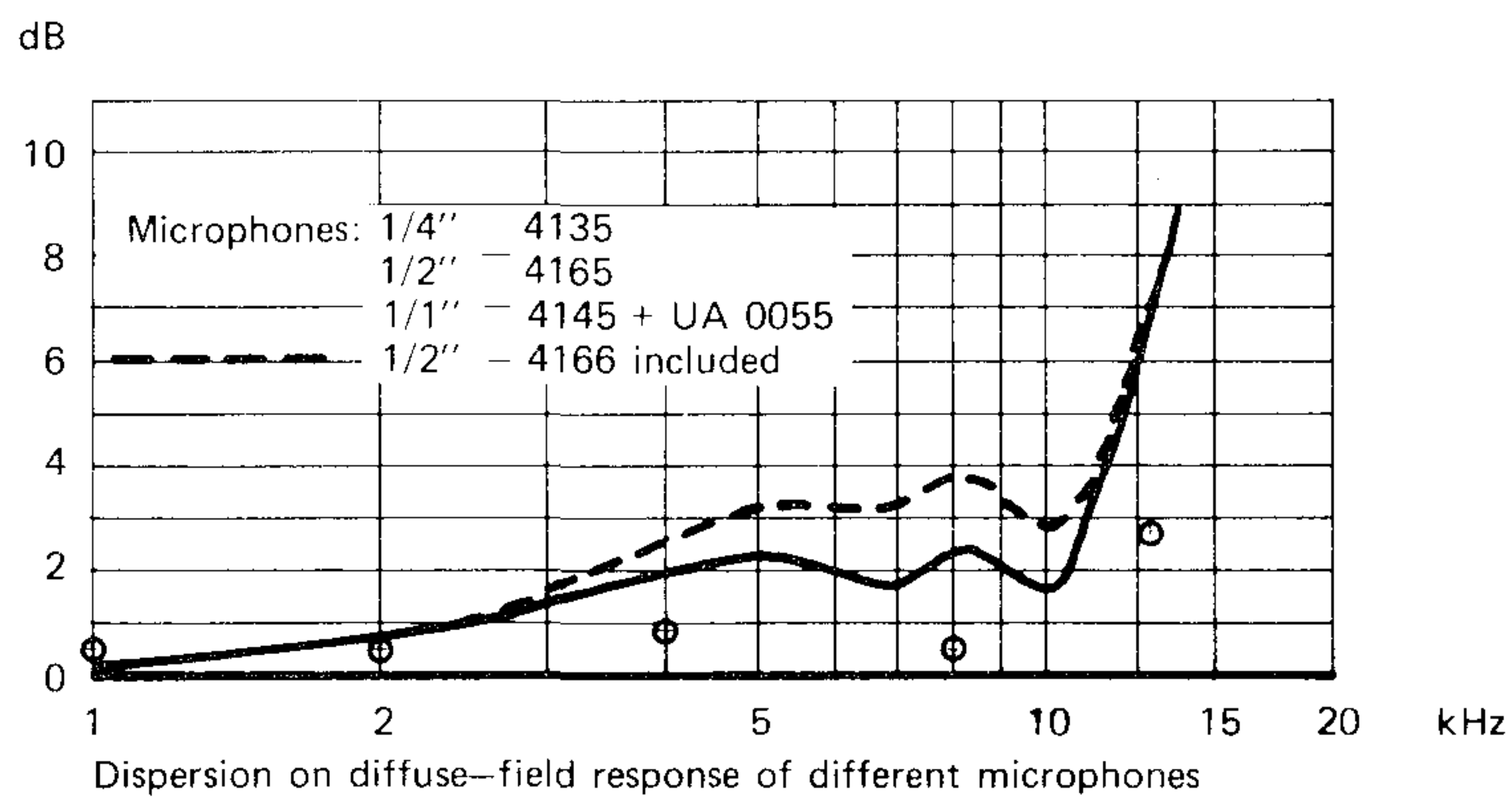
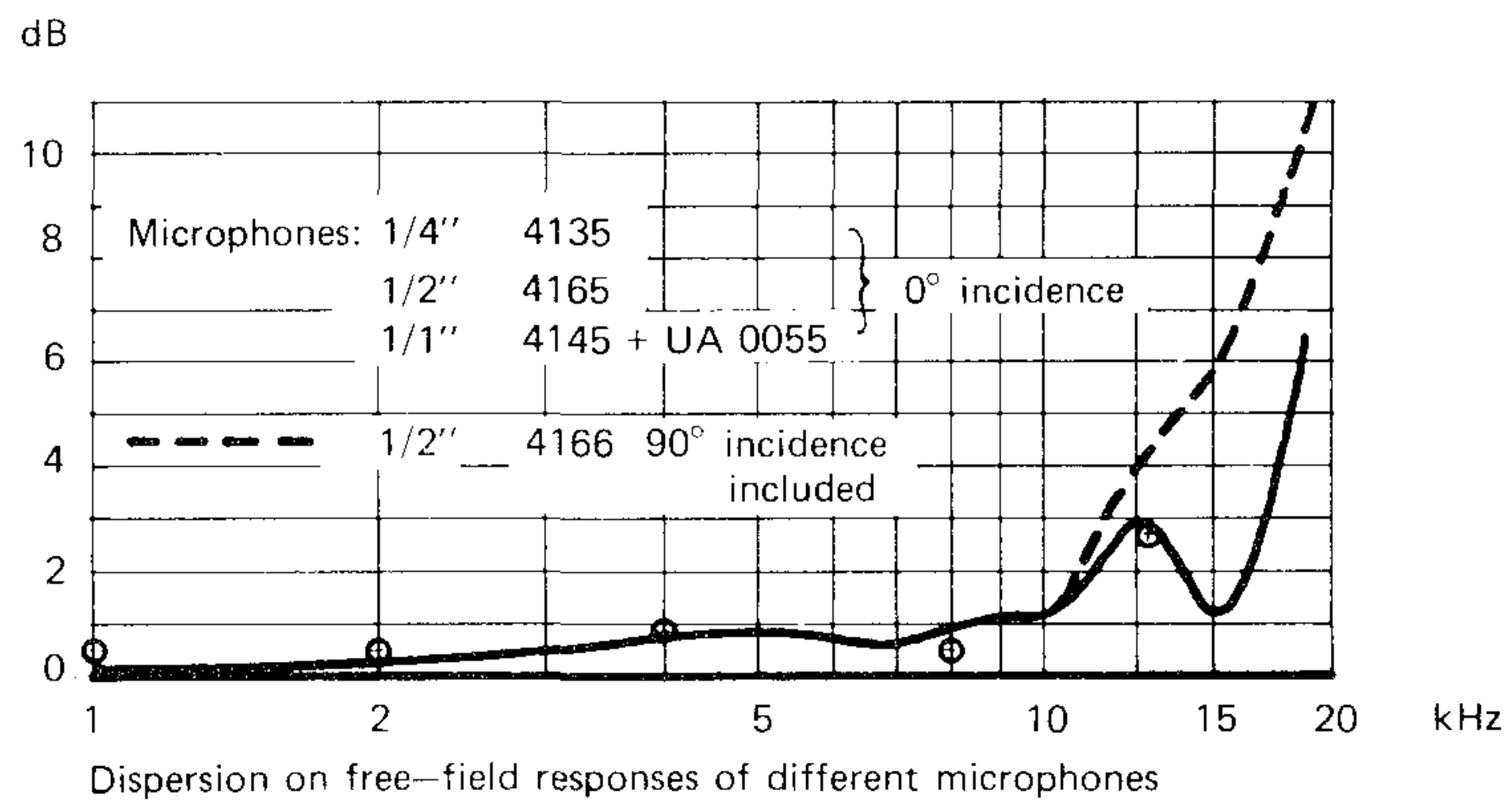
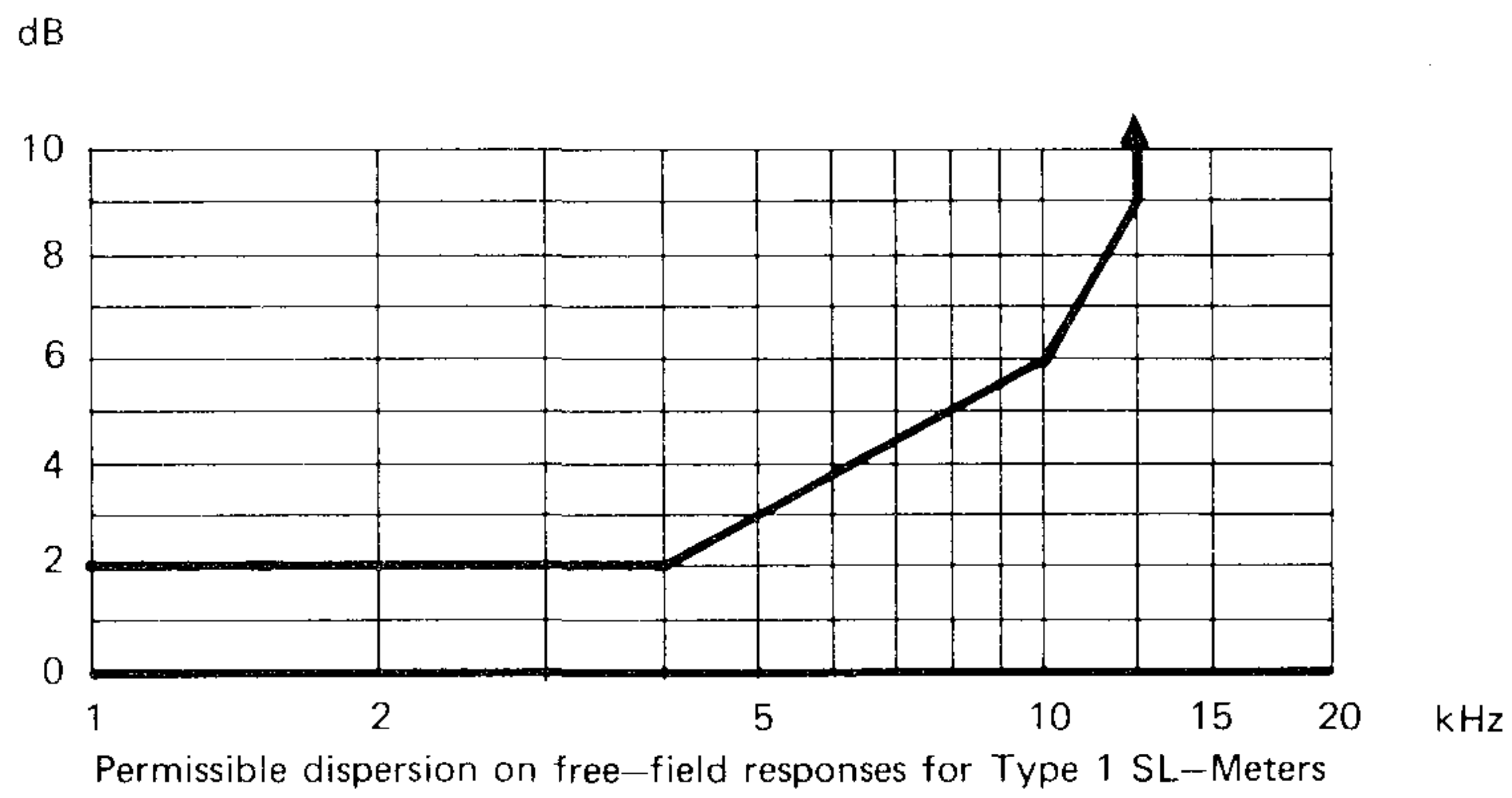

770617

Fig.3. Comparison between permissible spread of free-field frequency response for Type 1 SL-Meters and actual spread due to different microphone sizes and shapes. Spread of results from the measuring situation shown in Fig.4 are shown with circles

An ideal diffuse sound field is a hypothetical situation, just as is a completely free sound field. For outdoor measurements the sound will more often than not come from a certain direction, while for indoor measurements of noise a more diffuse field can be expected. This does not mean, however, that the direction of the microphone is unimportant.

A situation (Fig.4) may well arise, where instead of the direct sound dominating, the reflections from a wall may contribute to a dominating direction for the sound.

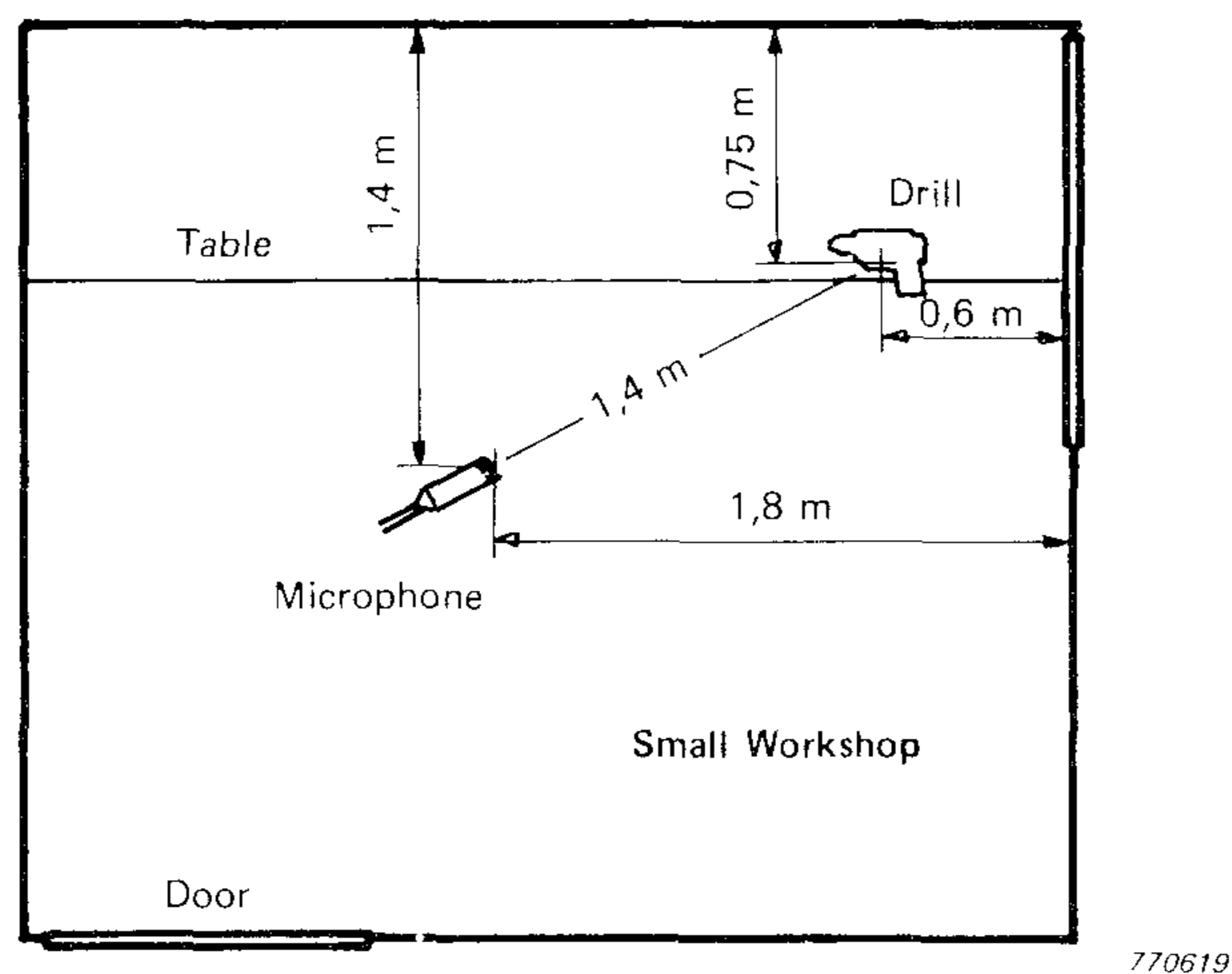
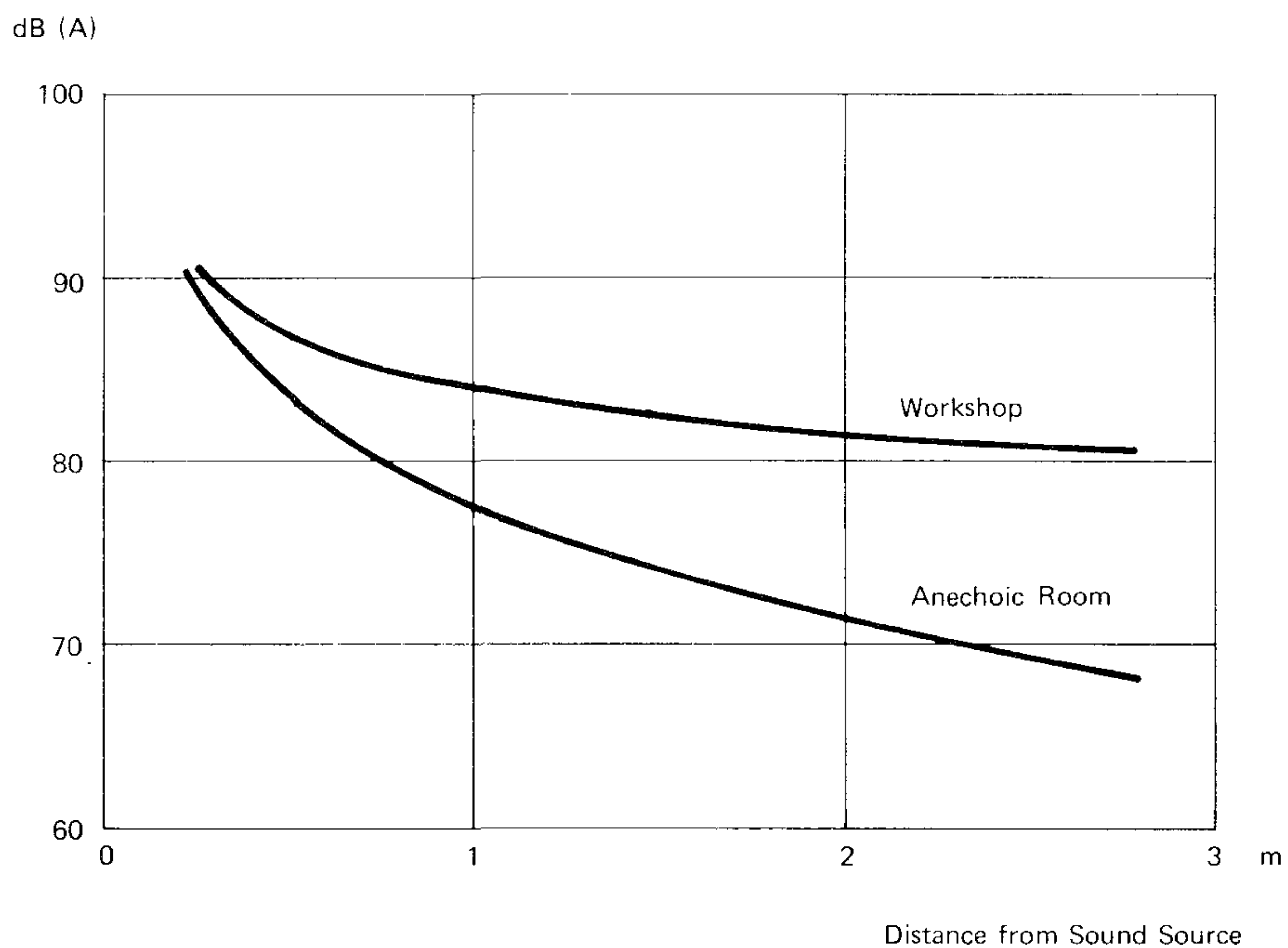
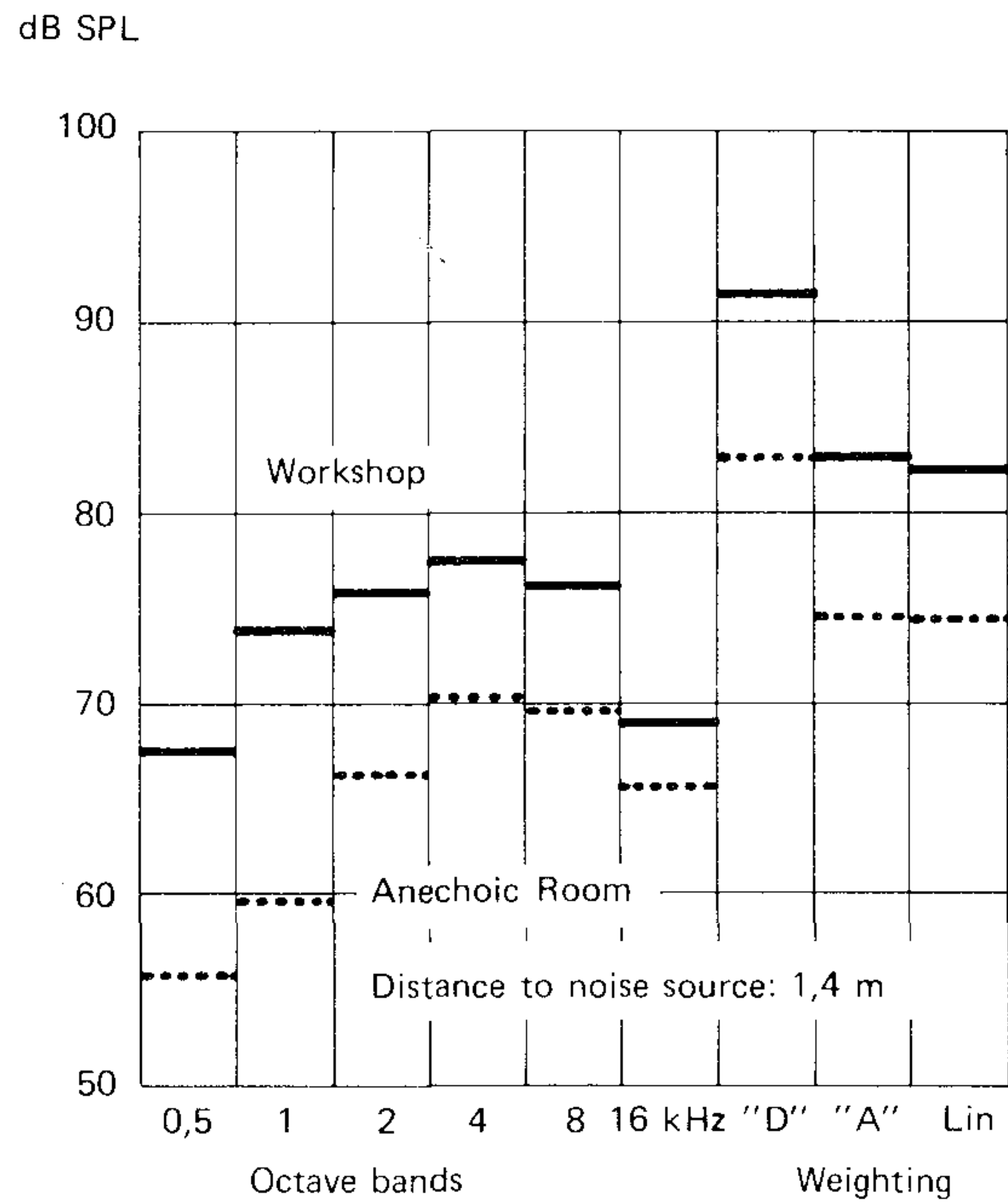

Fig.4. Sketch of a measuring situation

The noise from a hand drill was measured at a distance of 1,4 m in a small workshop and the results obtained in octave bands. D, A and Lin weighting are shown in Fig.5. For comparison, the noise spectrum of the *same* noise source at the *same* distance, but measured in an anechoic room, is also shown (with dotted lines). The lower graph in Fig.5 shows the A-weighted noise as a function of distance from the noise source. From the graphs a fairly diffuse field should be expected and therefore rather different measured results, if different sizes of microphones are used. In actual fact, the results from measurements carried out with microphones with sizes from 1/4" to 1" spread very little as shown in Fig.6 and not more than should be expected from their free-field characteristics.

The spread in the results of Fig.6 are plotted in the graphs of Fig.3 and are indicated by circles.

This example shows that even indoors, where one would expect the sound field to be rather diffuse, it is important to point the microphone with its reference direction at the sound source. This is a relatively simple matter when hand-held sound level meters are used, as the correct orientation can be checked on the spot, but if the microphone is firmly mounted, and an extension cable used to remove the instrumentation



770620

Fig.5. Comparison between measured noise in workshop and noise from the same source measured in an anechoic room

and the observer from the sound field in an attempt to improve the measuring accuracy, an error may be introduced, if a wrong orientation of the microphone is chosen by accident. This is in particular true if a "random" or "diffuse-field" microphone is chosen.

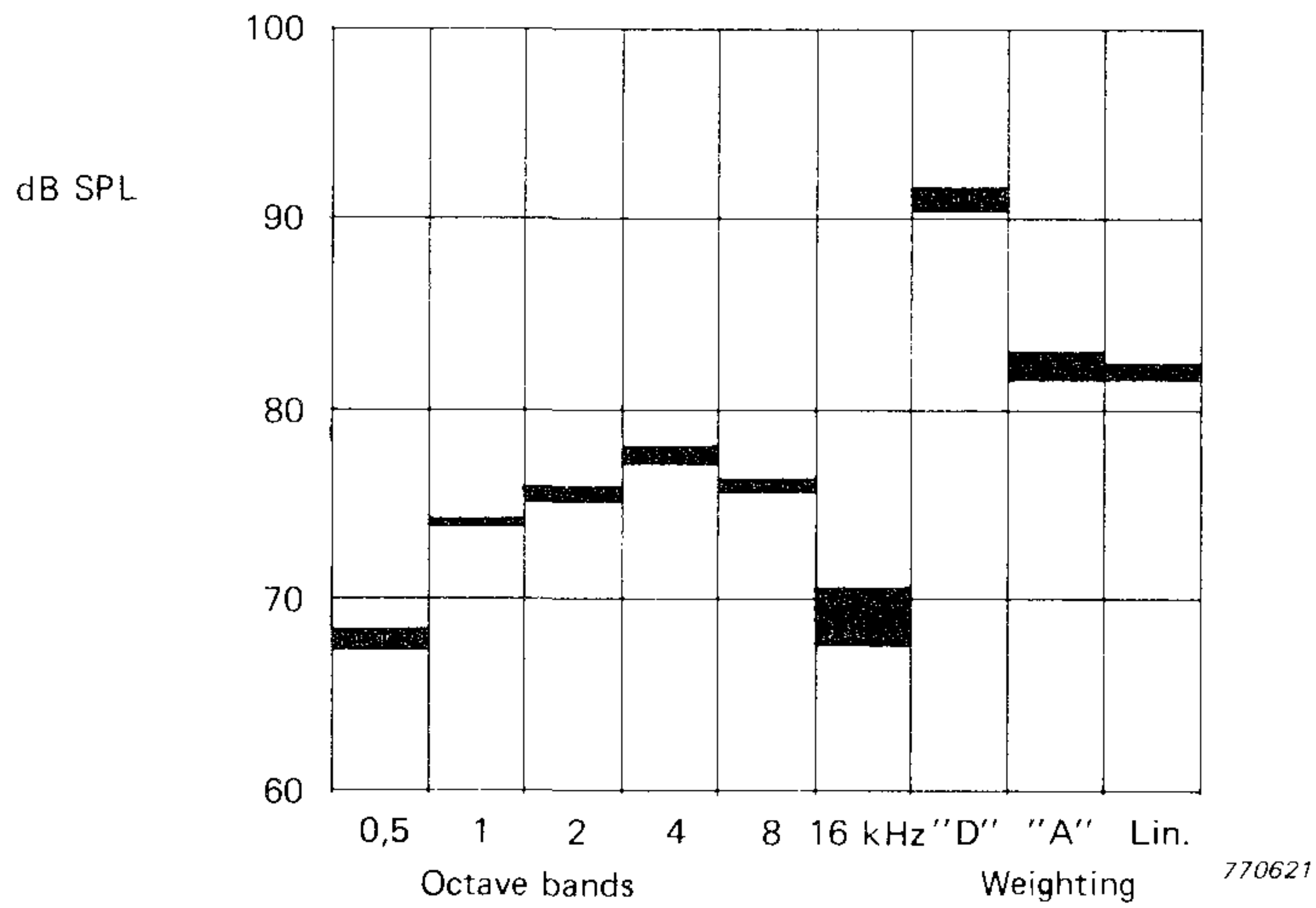

Fig.6. Measuring results from the situation shown in Fig.4. Spread due to use of different microphones

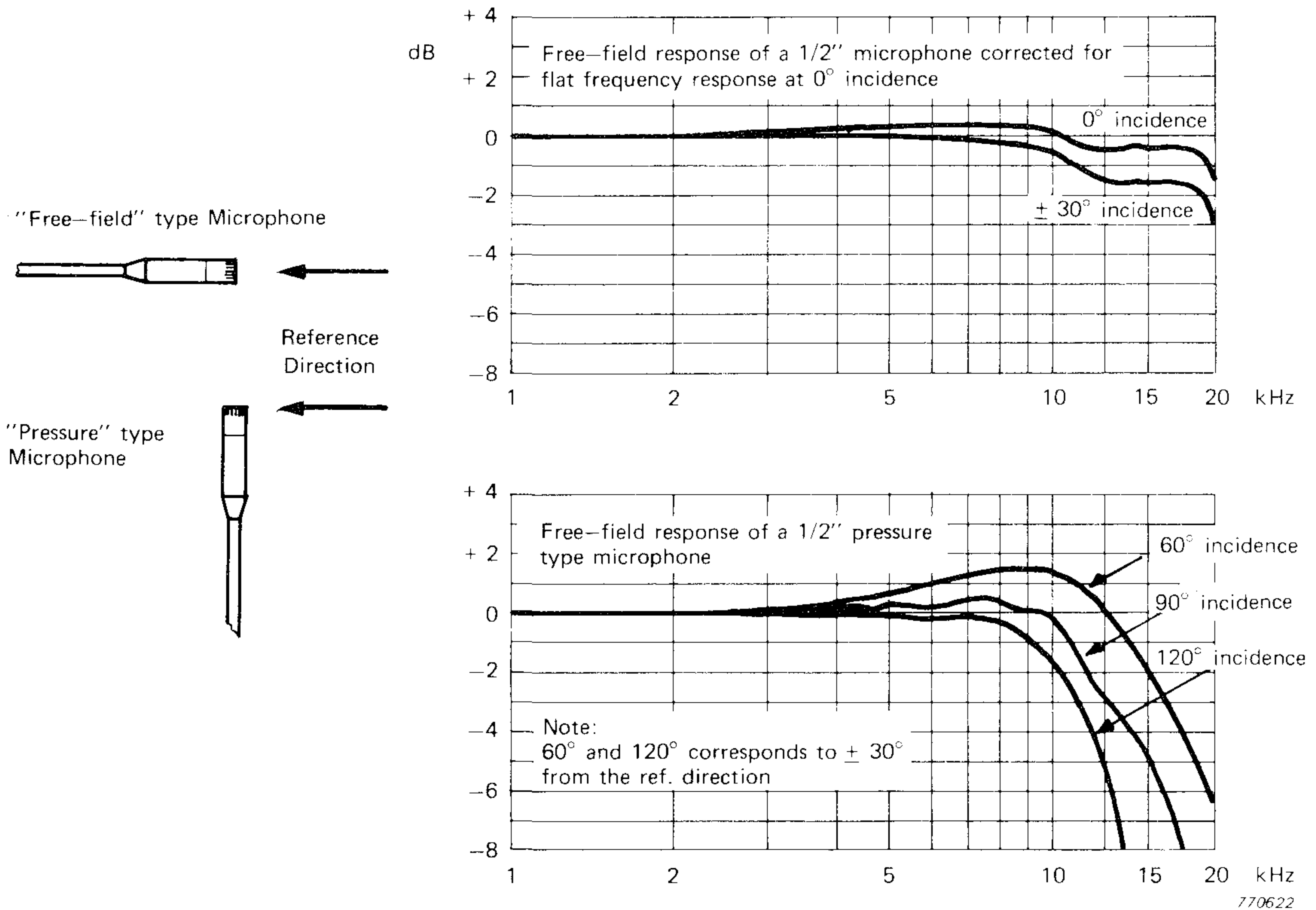

Fig.7. Comparison between the free-field frequency response of a "Free-field" and a "pressure" type microphone and their sensitivity deviations due to small changes in the angle of sound incidence from the reference direction

Fig.7 shows the sensitivity variation for two 1/2" microphones, the upper graph for "free-field" microphone and the bottom one for random type. Note that the change in sensitivity is much smaller for the "free-field" microphone than for the "diffuse" or "random" type. This means that the latter must be much more carefully oriented. Which microphone system is most correct or accurate has more academic than practical value, but it would be preferable if only one system was chosen throughout the world.

Consequences of ill-defined impulse response

To check and compare the impulse response of different sound level meters, the set-up shown in Fig.8 was used. Two of the sound level meters were precision types, two of them impulse precision, and one designed to meet IEC Type 0 specifications. The inputs of the instruments could be electrically connected to either a tone-burst generator to check

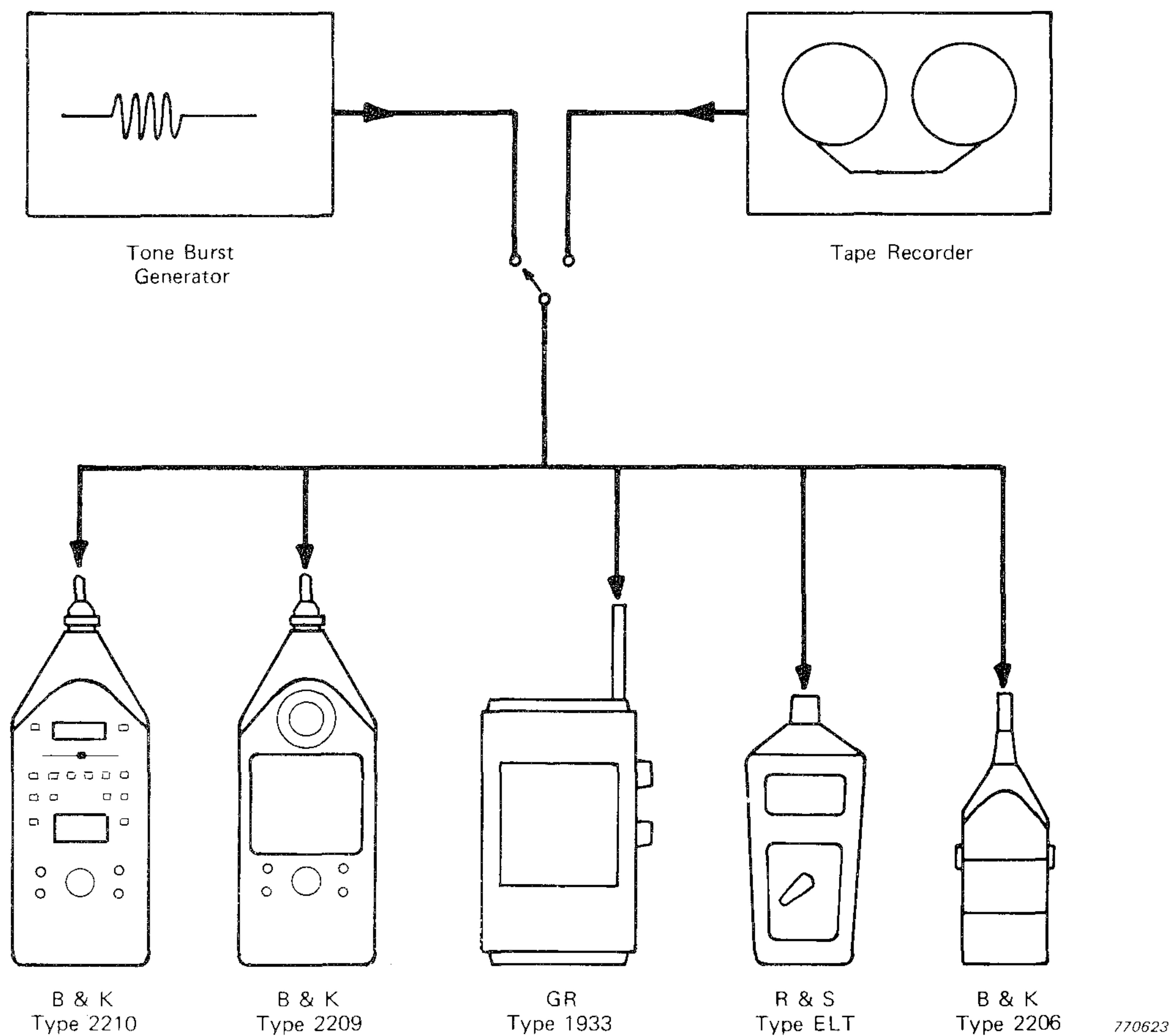

Fig.8. Set-up for measuring the impulse response of Sound Level Meters of different Types and manufacture

their performance under well-defined conditions, or a tape recorder. Several different types of noise were recorded on the tape, some of them constant and some with more or less impulsive content. All readings from the indicators were relative to the same electrical reference signal, and all readings were max. meter deflections in "Fast" mode.

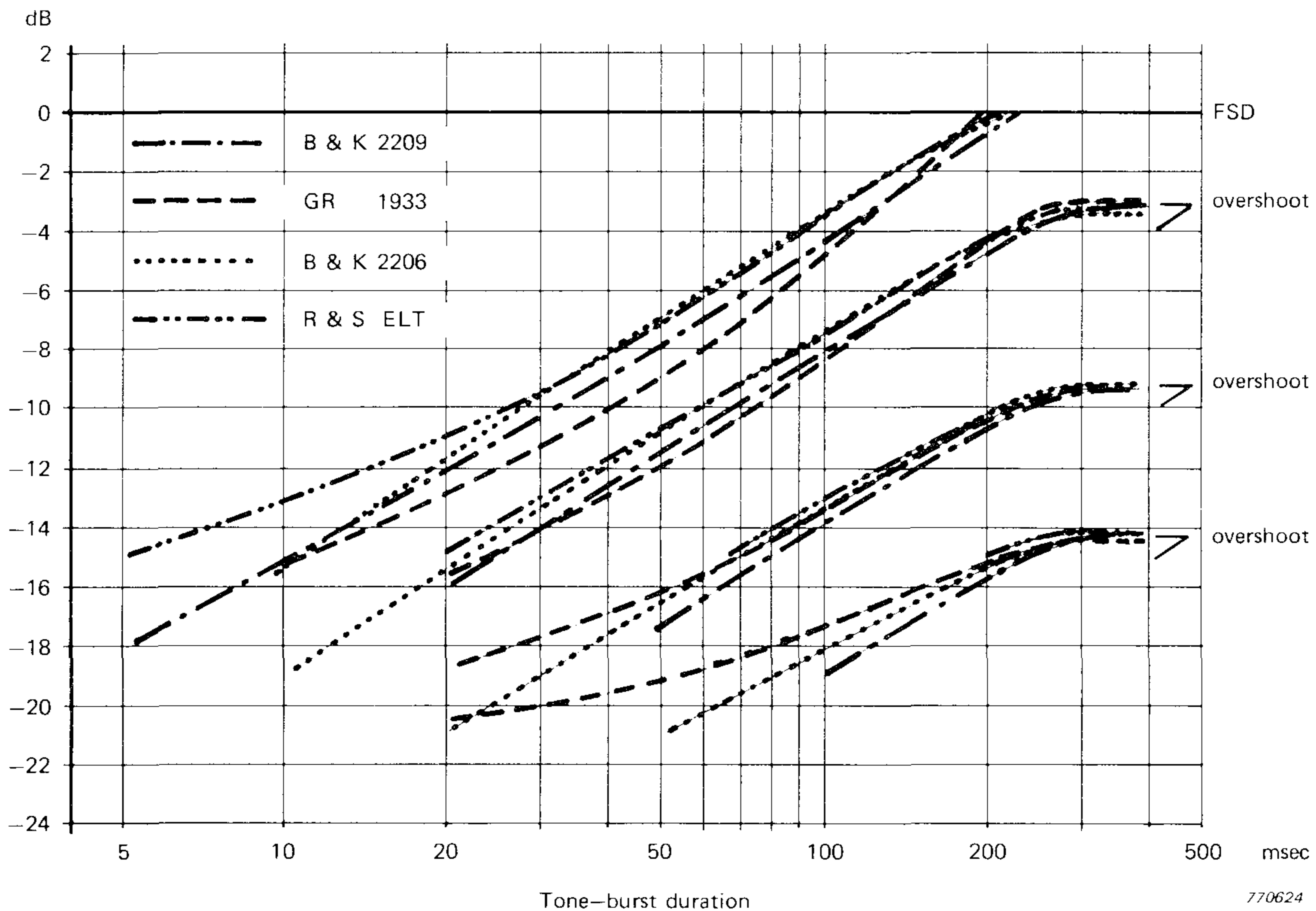

Fig.9. "Fast" response of different Sound Level Meters to a 2 kHz tone-burst. Reference is a continuous 2 kHz tone with same amplitude as for the burst. Reference levels are FSD and 4, 10 and 15 dB below FSD

The results of the tone-burst test are shown in Fig.9. Various reference settings were used to check the variations in the dynamic behaviour for different meter scale deflections. Note especially, that for this test there was no significant difference between precision sound level meters and impulse precision sound level meters.

The curve drawn in Fig.9 based on a reference setting of 4 dB below FSD is reproduced in Fig.10. The continuous line corresponds to the nominal response of an RMS detector system with 125 ms R-C time constant. This is the design goal or ideal response for "Fast" as now de-

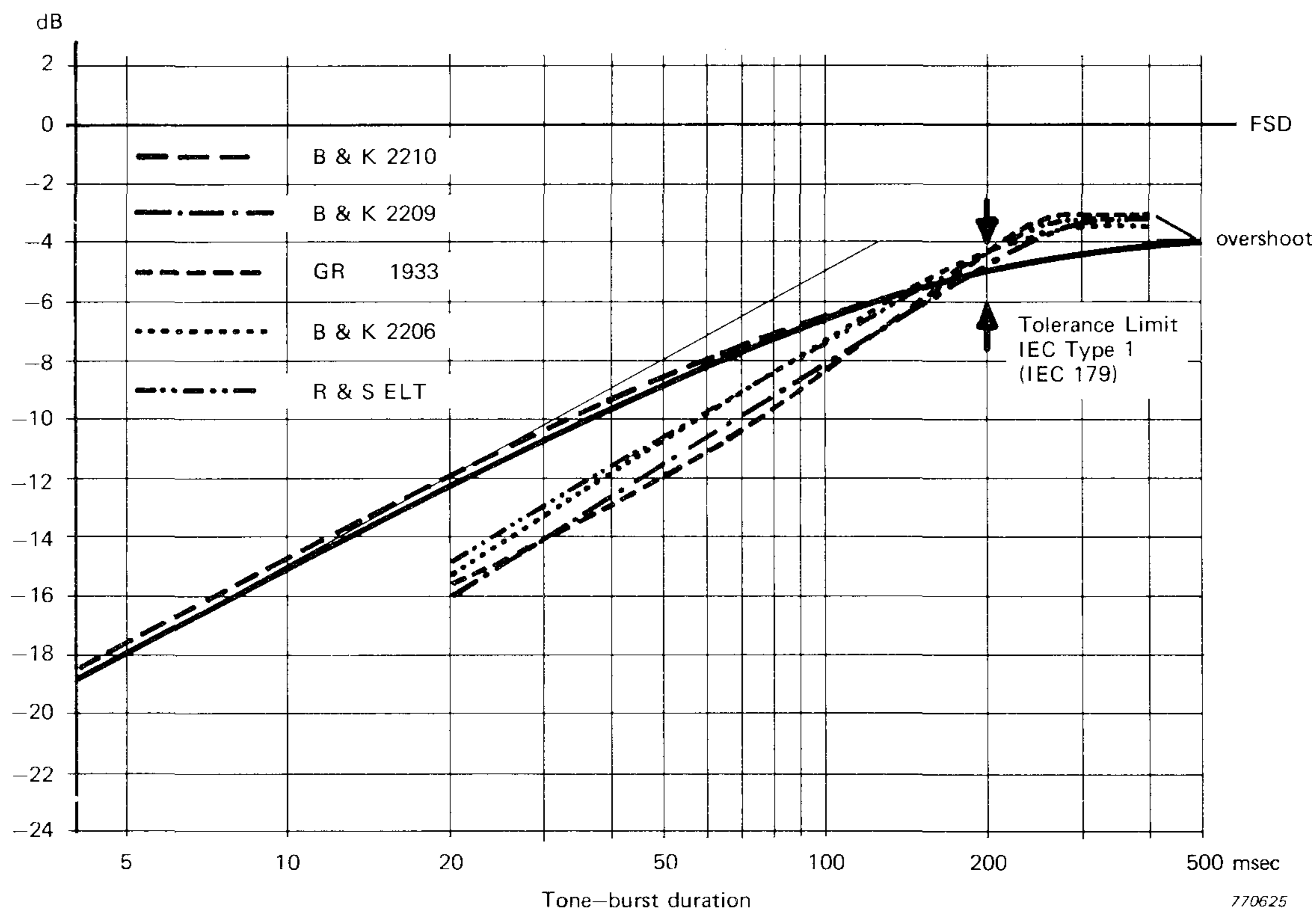

Fig.10. "Fast" response of different Sound Level Meters to a 2 kHz tone-burst. Reference is a continuous 2 kHz tone with the same amplitude as for the tone-burst. Reference level is 4 dB below FSD

scribed in the consolidated revision of the IEC Sound Level Meter standard. It should be noted that, although all of the instruments meet the precision standard, the responses in these practical cases have a spread of up to 4 dB. Only the instrument designed to meet the Type 0 specifications has a response close to the ideal.

It must be pointed out that the precision sound level meter in its "Fast" mode is *not* intended to be used for impulse sound measurements. However, as pointed out earlier, most noises have some impulse content and it may be difficult for the user of the instrument to judge this.

Fig.11 shows the responses of the five sound level meters, when different types of noises are measured in the "Fast" mode. From the results it can be seen that differences of up to 3 dB occur for the signal which has the most fluctuations. Note that the Type 0 instrument in general gives slightly higher readings, as expected. The only exception is the sit-

uation with the passing car, where the mechanical meters, due to their specified overshoot, gave a slightly higher reading than the Type 0 instrument.

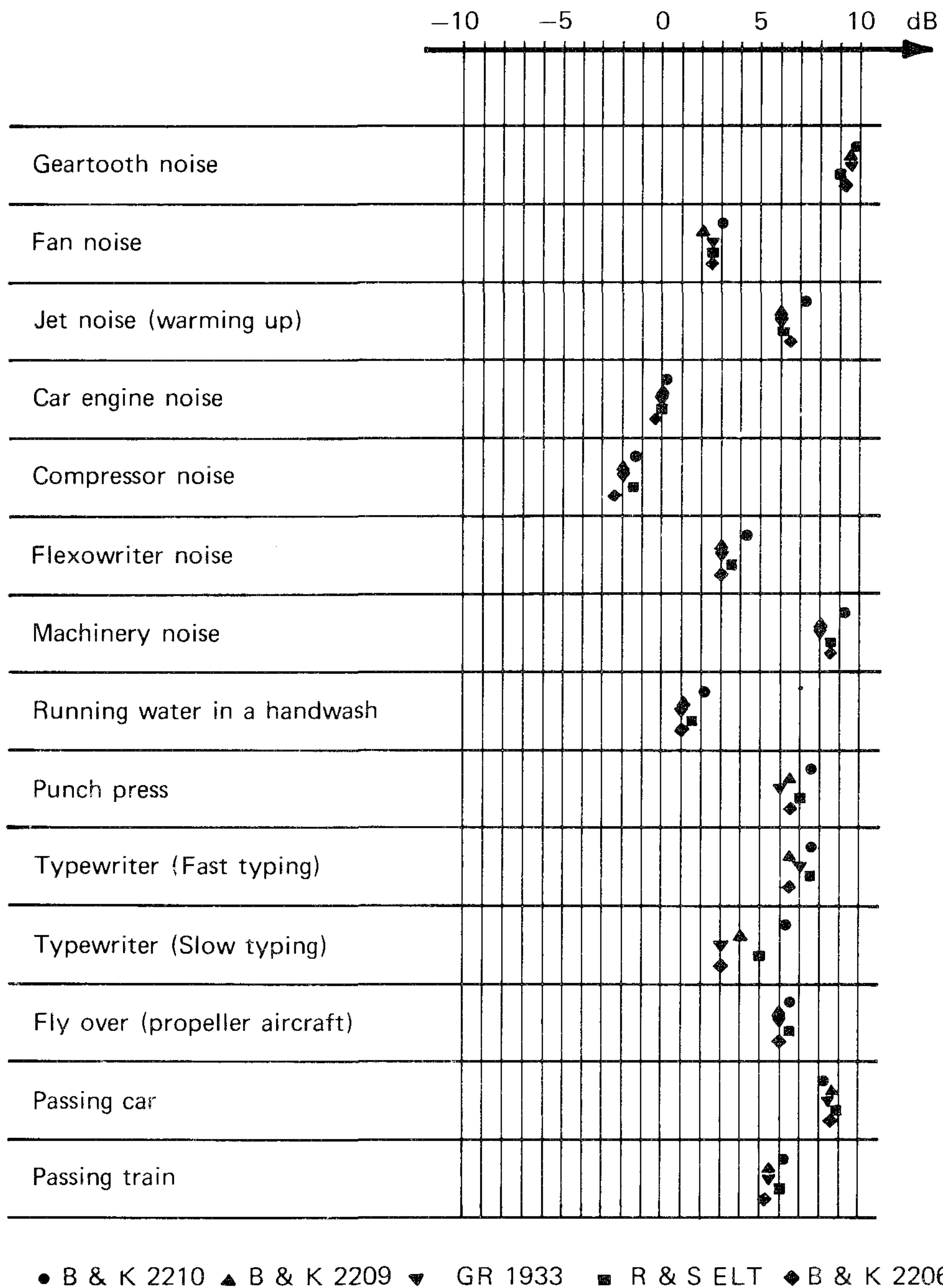

770414

Fig.11. Response of different Sound Level Meters to noise of different character (measured in IEC "Fast" mode)

| Accuracy of Type 0 and Type 1 SLM | | | | |
|-----------------------------------|---------|--------|------------------|--------|
| | Typical | | Tolerance Limits | |
| | Type 0 | Type 1 | Type 0 | Type 1 |
| Abs. accuracy at Ref. conditions | ± 0,2 | ± 0,3 | ± 0,4 | ± 0,7 |
| Microphone frequency response | ± 0,4 | ± 0,5 | | |
| Frequency Weighting (100–400 Hz) | | | ± 0,7 | ± 1,0 |
| Linearity | ± 0,4 | ± 0,5 | ± 0,4 | ± 0,7 |
| Detector (Noise) | ± 0,2 | ± 0,3 | ± 0,5 | ± 0,5 |
| $\sqrt{a^2 + b^2 + \dots + n^2}$ | ± 0,7 | ± 1,0 | ± 1,0 | ± 1,5 |

770415

Fig.12. *Estimated uncertainty for Type 0 and Type 1 SLM. (Exclusive of uncertainties due to different microphone directional characteristics and due to impulse response characteristics)*

Fig.12 shows estimated uncertainties for Type 0 and Type 1 Sound Level Meters. The estimated figures *do not cover* the uncertainties described for the impulse response or those due to the different directional characteristics of the microphones, and would be an additional factor in contributing to the overall inaccuracy.

Conclusion

It has been shown that in situations where the direction of the sound is difficult to ascertain or when the signals fluctuate, inaccuracies may occur in the measurement results obtained even with a precision sound level meter.

The Type 0 specifications as described in the consolidated IEC standard proposal will have significance not only because of their increased accuracy for ordinary situations, but to a higher degree for more difficult situations. This is likely to be important, especially in the future, when the legislation in the noise pollution area and the very great costs often connected with a particular noise reduction program will give rise to increased accuracy requirements and thereby to a sound level meter with improved performance.

Low Impedance Microphone Calibrator and its Advantages

by

Erling Frederiksen

ABSTRACT

Pistonphone type of calibrators which are often individually designed are used in laboratories as standard sound sources for pressure transducer calibration. They are normally limited to operate at individual frequencies and sound pressure levels. A more flexible calibration system has been developed which covers many of the pistonphone applications and gives additional possibilities for evaluation of pressure transducers. The article describes the operating principle of the system and some of its advantages over the pistonphone.

SOMMAIRE

Les étalonneurs du type pistonphone qui sont souvent construits individuellement sont utilisés en laboratoire comme source acoustique normalisée pour l'étalonnage des capteurs de pression. Ils ne peuvent normalement fonctionner qu'à des fréquences et des niveaux de pression sonore individuels. Un système d'étalonnage plus souple couvrant bon nombre des applications du pistonphone et fournissant des possibilités supplémentaires d'évaluation des capteurs de pression a été développé.

Cet article décrit le principe de fonctionnement du système et certains de ses avantages par rapport au pistonphone.

ZUSAMMENFASSUNG

Pistonfonkalibratoren, die oft individuell konstruiert sind, werden im Labor als Bezugsschallquellen benutzt, um Druckwandler zu kalibrieren. Ihr Betrieb ist normalerweise auf eine bestimmte Frequenz und einen bestimmten Schalldruck begrenzt. Ein flexibleres Kalibriersystem wurde entwickelt, das viele der Anwendungsgebiete der Pistonfone abdeckt und zusätzlich Möglichkeiten zur Bewertung von Druckwandlern bietet. In diesem Artikel werden Arbeitsprinzip und einige der Vorteile gegenüber dem Pistonfon diskutiert.

Introduction

High pressure and low frequency calibration of microphones are normally carried out with the use of pistonphone type of calibrators which work on a fundamental physical principle. They are often individually designed and under carefully controlled conditions allow accurate calibration of microphones. However, their operation is limited to single frequencies and sound pressure levels. For universal calibration of microphones and pressure transducers a High Pressure Microphone Calibrator Type 4221 has been designed which has several important features compared to a pistonphone. It covers the frequency range from 1 mHz or lower to 1000 Hz and generates sound pressure levels up to 172 dB (re. $20 \mu\text{Pa}$). To evaluate the background for the development of this system, the problems encountered in the pistonphone design are first discussed and it is shown how they are overcome or minimized in the design of the 4221.

Pistonphone Principle

In a pistonphone, a mechanically driven piston with controlled volume displacement operates into a closed cavity of known volume. The dynamic pressure generated in the cavity can be calculated from the following equation:

$$p = p_0 \left[1 - \frac{\gamma \Delta V}{V_0} \sin \omega t + \frac{\gamma (\gamma + 1)}{2} \left(\frac{\Delta V}{V_0} \right)^2 \sin^2 \omega t \dots \right]$$

i.e.

$$p = p_0 \left[1 - \frac{\gamma \Delta V}{V_0} \sin \omega t + \frac{\gamma (\gamma + 1)}{4} \left(\frac{\Delta V}{V_0} \right)^2 (1 - \cos 2\omega t) \dots \right] \quad (1)$$

where p_0 = ambient pressure
 γ = ratio of specific heats for the gas (for air 1,402)
 ΔV = volume displacement
 V_0 = volume of cavity.

To obtain an accurate value of the pressure the following four conditions must be fulfilled as closely as possible in practice,

- a) sinusoidal piston displacement
- b) small dimensions of the cavity
- c) a pure adiabatic process
- d) an airtight cavity (no leakage).

- a) Using special mechanical construction, sinusoidal piston displacement can be obtained and is best achieved at relatively large volume displacement giving high sound pressure levels. It is almost impossible to design a simple system giving a continuously variable and yet a controlled volume displacement. Also most of the pistonphones are limited to frequencies below 100 Hz as operation of such systems at high frequencies induce high vibration levels having adverse effects on the pistonphone itself and the transducers being calibrated.
- b) The dimensions of the cavity should be small in order to avoid the influence of wave motion or the need for implementing correction factors. However, it may conflict with the interest of having a controllable (suitably large) volume displacement especially when low sound pressure levels are required (100—120 dB). Also the distortion of an ideal pistonphone is a function of the ratio of volume displacement to cavity volume.

$$\text{Distortion (2nd harmonic)} = \frac{\gamma + 1}{4} \cdot \frac{\Delta V}{V_0} \cdot 100\% \quad (2)$$

- c) In practice a pure adiabatic process can be assumed at high frequencies. At low frequencies, however, temperature equalization takes place between the gas being compressed and the cavity walls, decreasing the sound pressure generated. Depending on the type of gas, frequency, volume, area of cavity walls etc. the change can be up to approximately 3 dB for air. This loss should be evaluated and normally taken into account for accurate calibration at all frequencies below 100 Hz.
- d) As the piston must glide in the cylinder, an airtight cavity may be difficult to achieve, which will influence the sound pressure level, especially at low frequencies.

From equation 1 it can be seen that the ambient pressure also influences the sound pressure generated. Most of the factors mentioned above need to be taken into consideration because of the fact that the source (the piston moving with constant displacement) has an infinitely high impedance applying an acoustic current to the load (the cavity volume having a certain leakage). The sound pressure generated is proportional to the load impedance which depends on the factors mentioned above. *

Principle of the High Pressure Microphone Calibrator 4221

In contrast to the pistonphone, the source impedance of this calibrator is very low compared to the impedance of the cavity (the load) into which it works. As a result the sound pressure generated would be to a significant degree independent of the factors mentioned in the section above that affect the load impedance.

The system consists of a basic unit and two different couplers, one for high pressure calibration and the other for low frequency calibration.

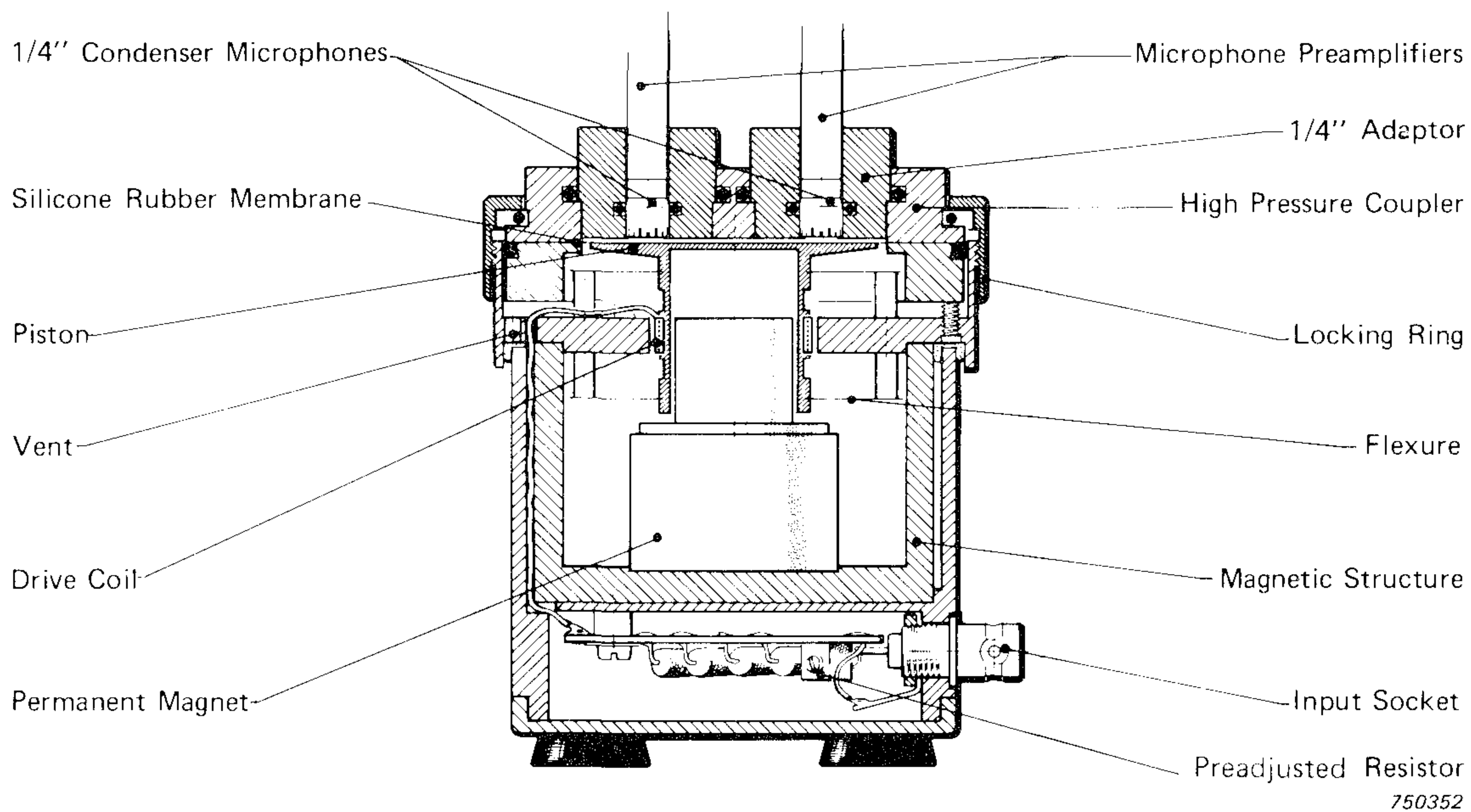

Fig.1. Cross Sectional View of Calibrator 4221

The basic unit shown in Fig.1 is an electrodynamic system in which a plane piston is mounted on the moving element. A ring is mounted flush with the piston surface on the stationary part of the system. A thin silicon rubber foil is mounted over the piston and the ring to make the system airtight and serves as a sealing for the coupler mounted. In order to obtain a low system impedance the flexures of the moving element were made soft and the mass was kept low. Since the acoustical impedance is inversely proportional to the square of the piston area it was made relatively large. However, the larger the piston area, the

* It should be noted that the B & K field and laboratory Pistonphone, Type 4220 is not made to a traditional design. Its special design gives stability and a low vibration level and the choice of its frequency and sound pressure level makes it a convenient calibrator for single point calibration.

lower would be the maximum sound pressure generated. As a compromise a diameter of 54 mm was chosen giving a compliance of $13 \cdot 10^{-9} \text{ m}^5/\text{N}$ (corresponding to an equivalent volume of 185 cm^3) and resulting in a maximum sound pressure level of 172 dB re. $20 \mu\text{Pa}$.

The force produced by the system is 4,2 N/Amp giving a conversion factor K of 1830 Pa/Amp when a piston area of $22,9 \text{ cm}^2$ is considered. Fig.2 shows the electroacoustical circuit of the system.

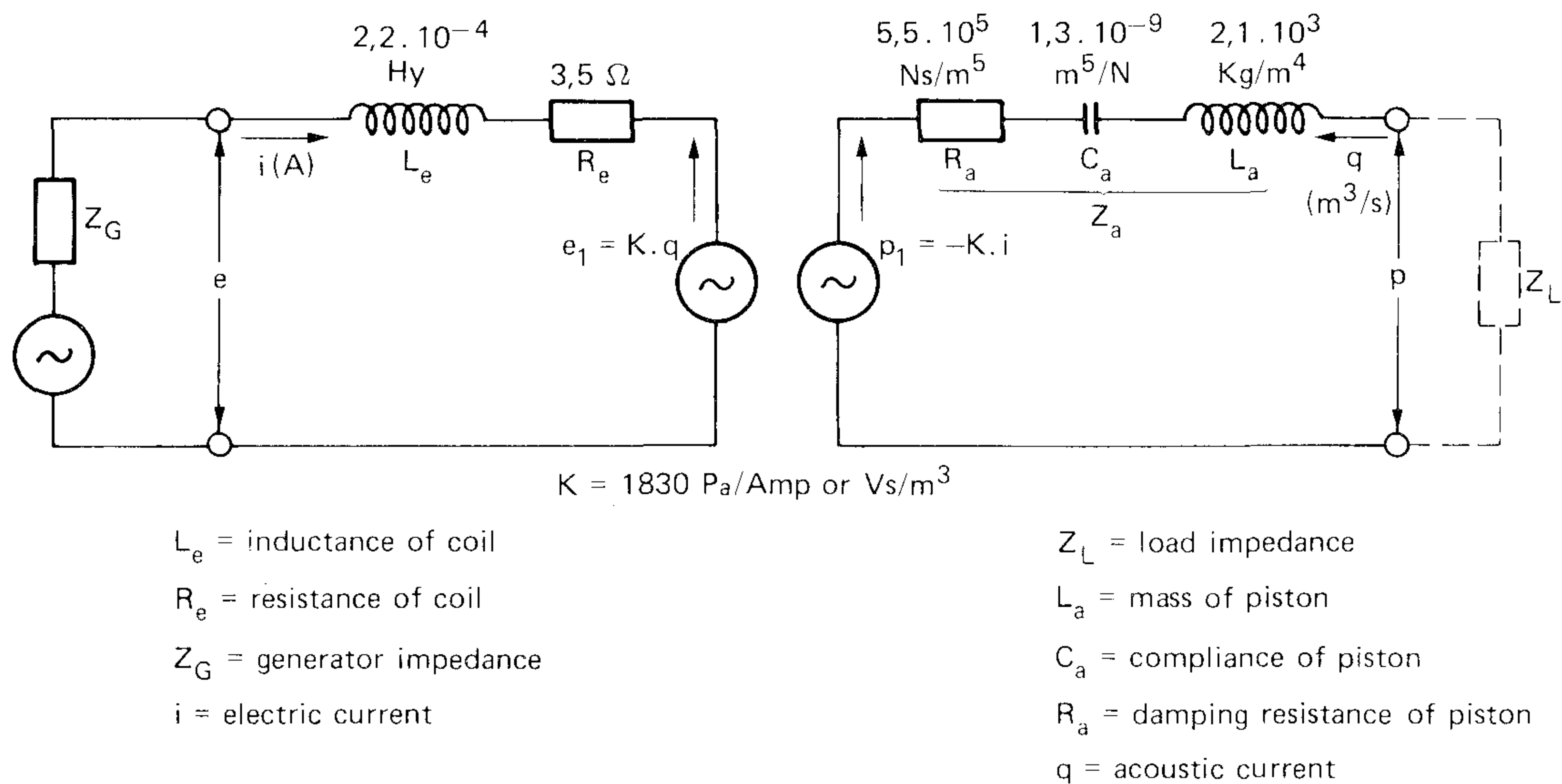

771067

Fig.2. Equivalent Circuit of Calibrator 4221

From the circuit it can be seen that the sound pressure developed over Z_L (i.e. in the coupler) is given by

$$p = (-K) i \frac{Z_L}{Z_a + Z_L} \quad (3)$$

or

$$p = \frac{(-K) i}{Z_a} \frac{Z_a Z_L}{Z_a + Z_L} \quad (4)$$

Equation (4) leads to the circuit shown in Fig.3 and it is obvious that the sound pressure is independent of Z_L as long as $Z_a \ll Z_L$.

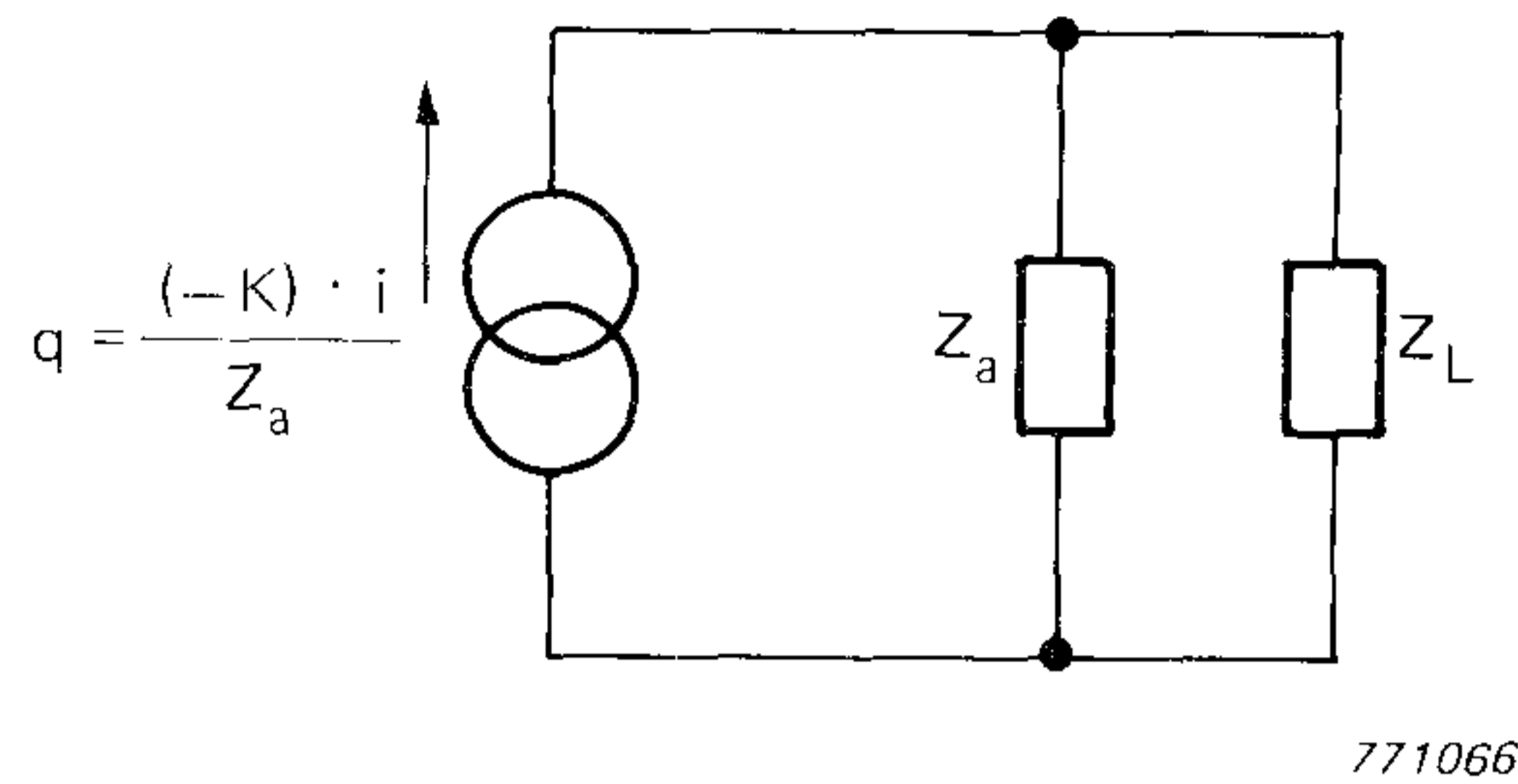

Fig.3. Simplified Equivalent Circuit of Calibrator 4221

It follows that even though the impedance of Z_L may vary due to ambient pressure changes or due to changes in cavity volume when different types of transducers are mounted, the sound pressure generated will be relatively unaffected. Also the change in the process from being adiabatic at high frequencies to isothermal at low frequencies will have practically no influence on the sound pressure. The leakage problem at low frequencies is also reduced considerably as the leakage resistance should be compared with the low impedance Z_a and not with the cavity impedance Z_L .

Wave motion correction is not necessary as the length of the cavity for the high pressure coupler is very short, a few tenths of a mm.

The short cavity length giving a small cavity volume implies a relatively high load impedance. As a result the piston displacement will be small and the vibration levels generated at the transducer position would be low. Since the displacement is only about $10\mu\text{m}$ at 154 dB and the mass of the moving element is very small in relation to that of the stationary part, the vibration level is low compared to that of pistonphone type of calibrators. This feature is very valuable when calibrating dynamic and piezoelectric transducers which have a high moving mass and therefore a high vibration sensitivity compared to condenser microphones.

Another advantage this system offers is that it has low distortion. It can be seen from Fig.3 that even if Z_L is non linear, the distortion will be low as the dominating load is Z_a .

At low frequencies this can be physically explained by the following: when a current is fed to a coil an electromagnetic force is generated and the piston deflects until a restoring force of same magnitude and opposite direction is developed. The restoring force is made up of two

components, one due to the stiffness of the flexures and the other due to the stiffness of the air cavity. If the flexure stiffness is kept small (as in the 4221) the cavity stiffness will dominate and the force due to the cavity stiffness will be directly proportional to the electromagnetic force. As a result, for a sinusoidal input the pressure in the cavity will vary sinusoidally, while the piston displacement will not be proportional to the electromagnetic force.

However, the distortion of the 4221 is only about 6 dB lower than that of a constant volume displacement system. It is not due to the acoustical principle, but caused by non-linear electromechanical coupling.

Pistonphone type of calibrators operate on a fundamental physical principle which make them suitable for absolute single point calibration in standard laboratories. The 4221, however, is a flexible system for universal calibration and evaluation of pressure transducers.

The detailed specifications and characteristics of this system can be found in the B & K application note "High Pressure Measurement with the High Pressure Microphone Calibrator Type 4221".

APPENDIX

Figs.A1 and A2 show the theoretical and measured impedance curves of 4221 in terms of equivalent volume as a function of frequency. The curves A are for constant voltage supply (low impedance electrical source) and curves B are for constant current supply (high impedance electrical source).

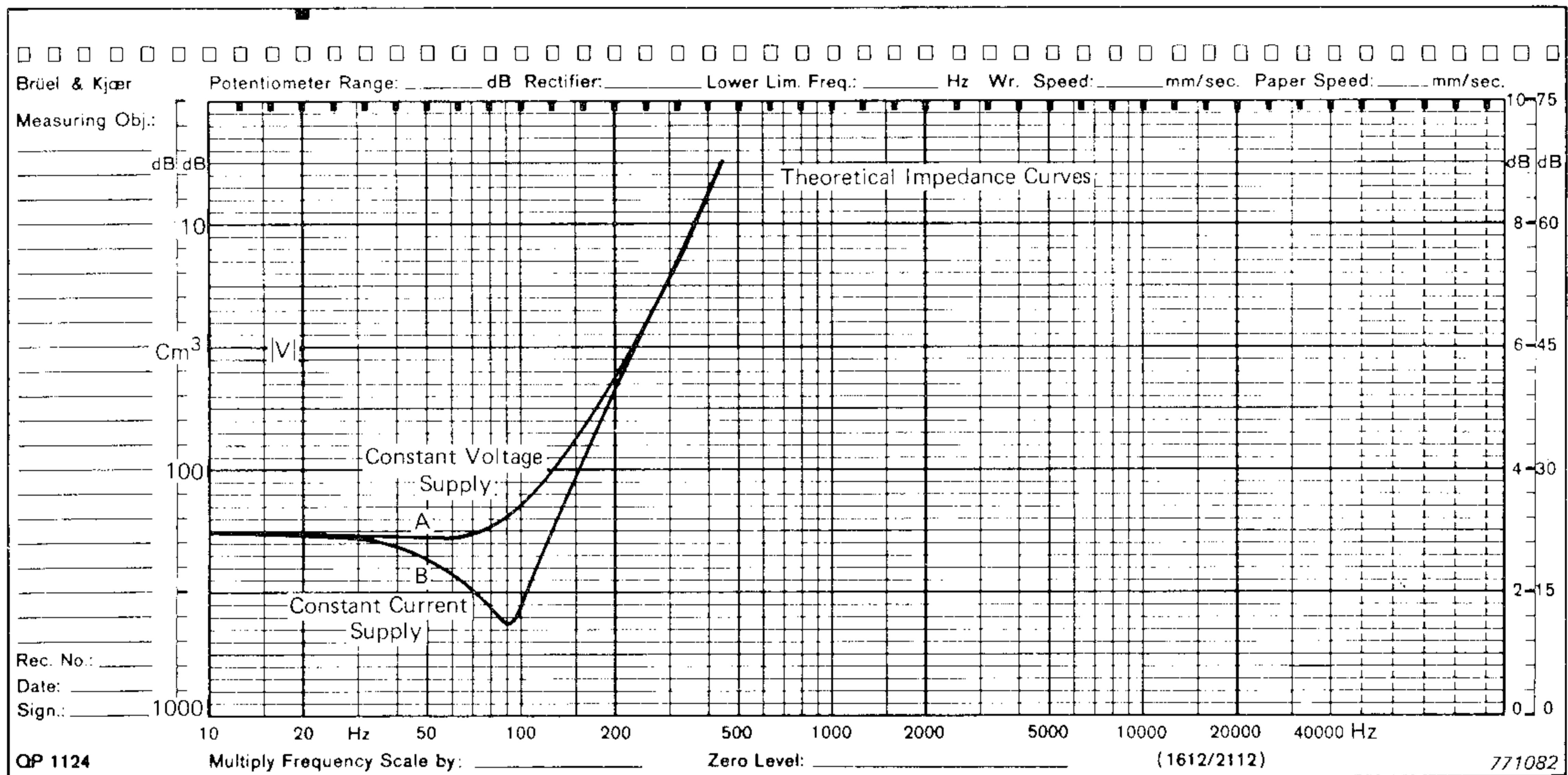

Fig.A1. Theoretical Impedance Curves of Calibrator 4221

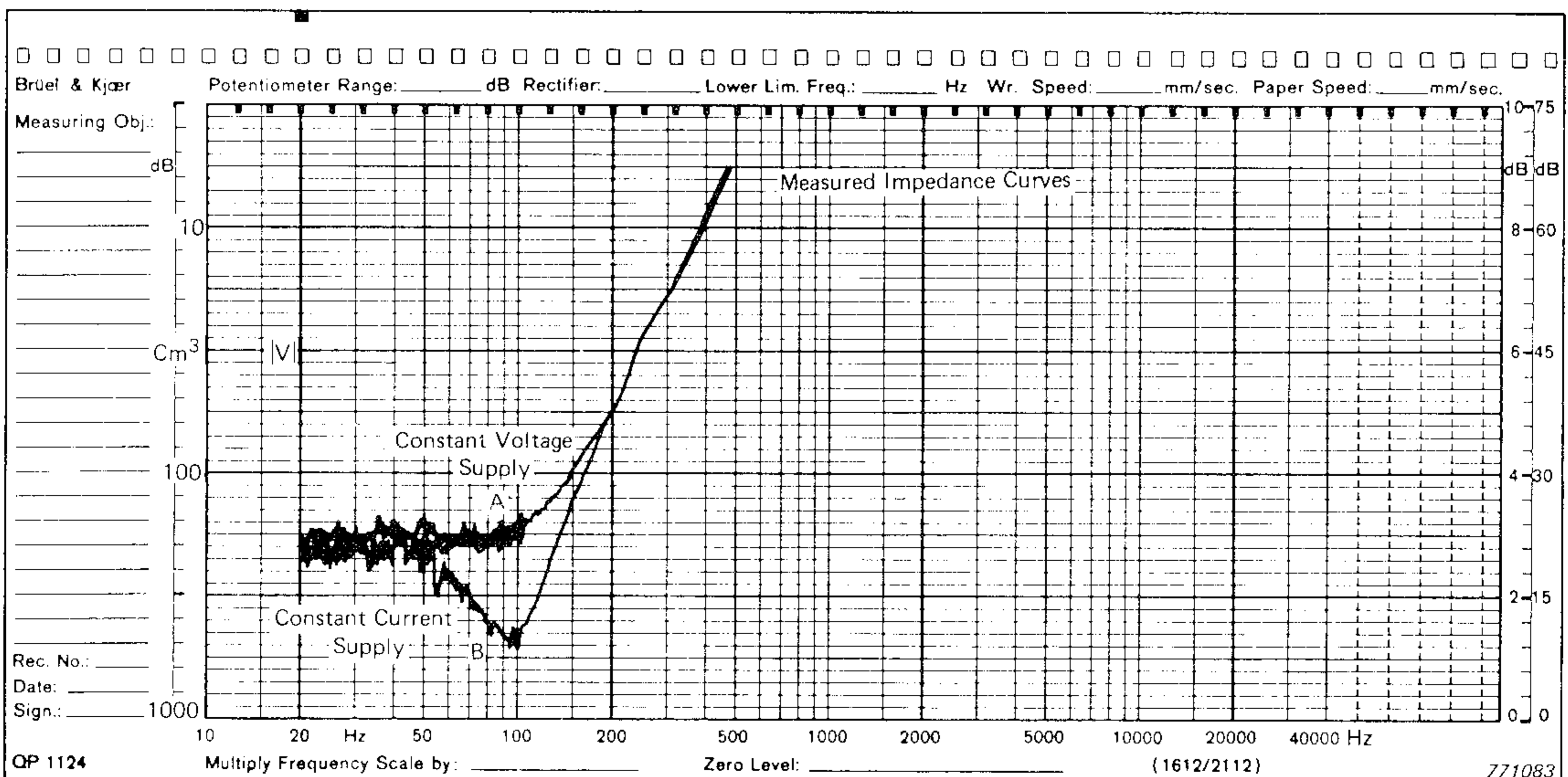
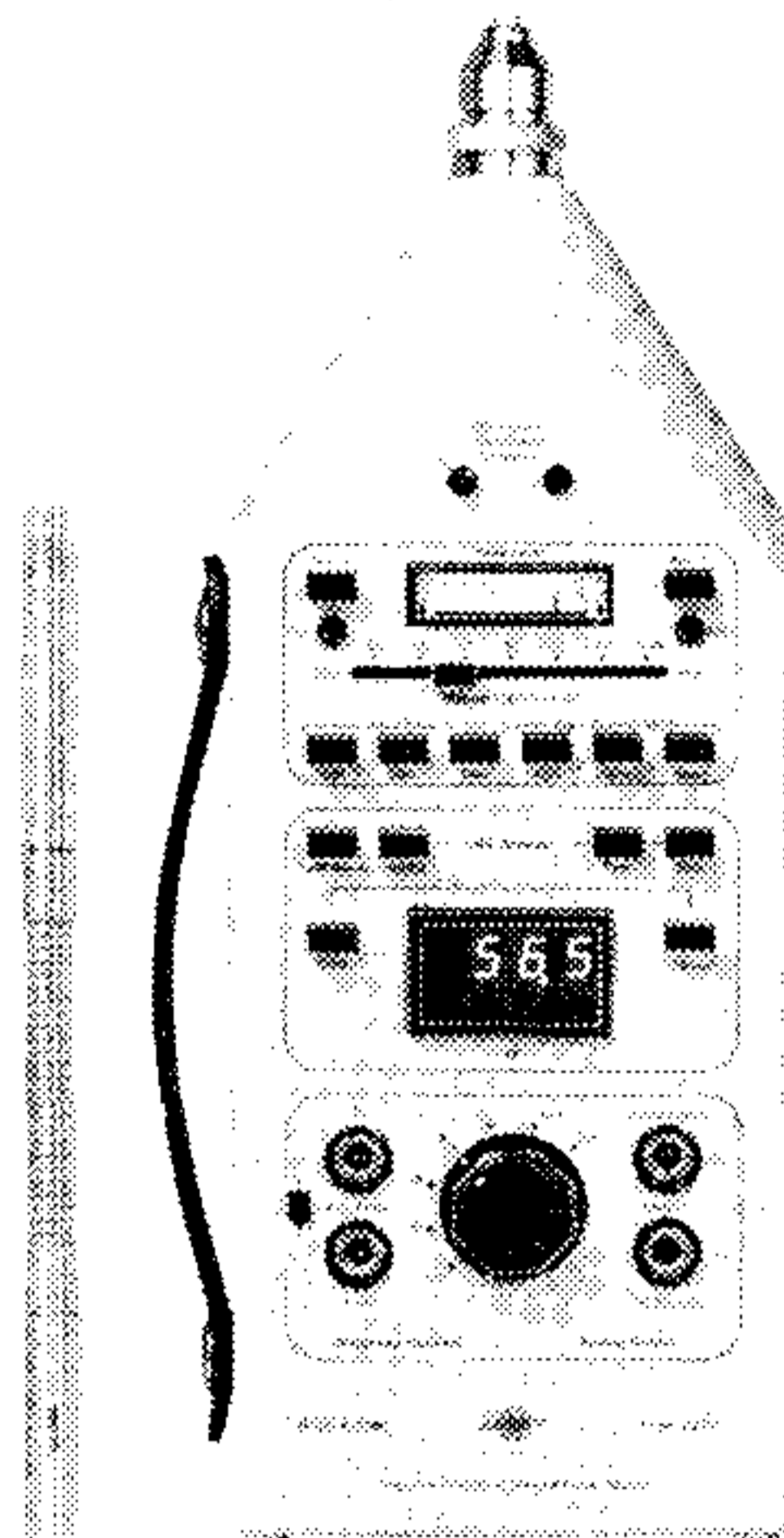

Fig.A2. Measured Impedance Curves of Calibrator 4221

News from the Factory

Impulse Precision Sound Level Meter with Digital Read-out Type 2210



The Digital Impulse Precision Sound Level Meter Type 2210 meets the requirements of the proposed Type 0 Laboratory Reference Standard as mentioned in the Consolidated Revision of IEC R 123 and R 179. The fulfilment of the rigorous requirements ensures repeatability in the measurement of impulsive or fluctuating noise.

The automatic gain control used extensively throughout the instrument, greatly simplifies its operation and provides a dynamic range of 90 dB(A). This wide range is also useful when the output of the instrument is fed to a Level Recorder Type 2306, Tape Recorder 7003/4 or the Alphanumeric Printer Type 2312.

The instrument is equipped with a bright 1/3", 4-digit gas discharge display which is easy to read and which practically eliminates reading errors. The displayed value is updated at intervals of either 0,1 s or 1 s or manually at will.

The response of the LMS detector can be switched to provide indication of sound level with the standardized "Fast", "Slow" or "Impulse" time

constants as well as the absolute peak value of the measured signal. As required by the standard the 2210 measures and stores the maximum value of the detected signal occurring in the sampling interval. By using the "Manual" sampling mode a max. hold facility operating in all detector modes is obtained. For ease of operation most functions are push button operated.

The internationally standardized A, B, C and D weighting networks are built-in. The instrument is equipped with facilities for connections to external filters whereby frequency analysis can be performed on weighted as well as unweighted signals.

A built-in reference generator enables easy electrical calibration of the instrument itself and of complete set-ups for tape or graphic recording.

Precision Integrating Sound Level Meter Type 2218

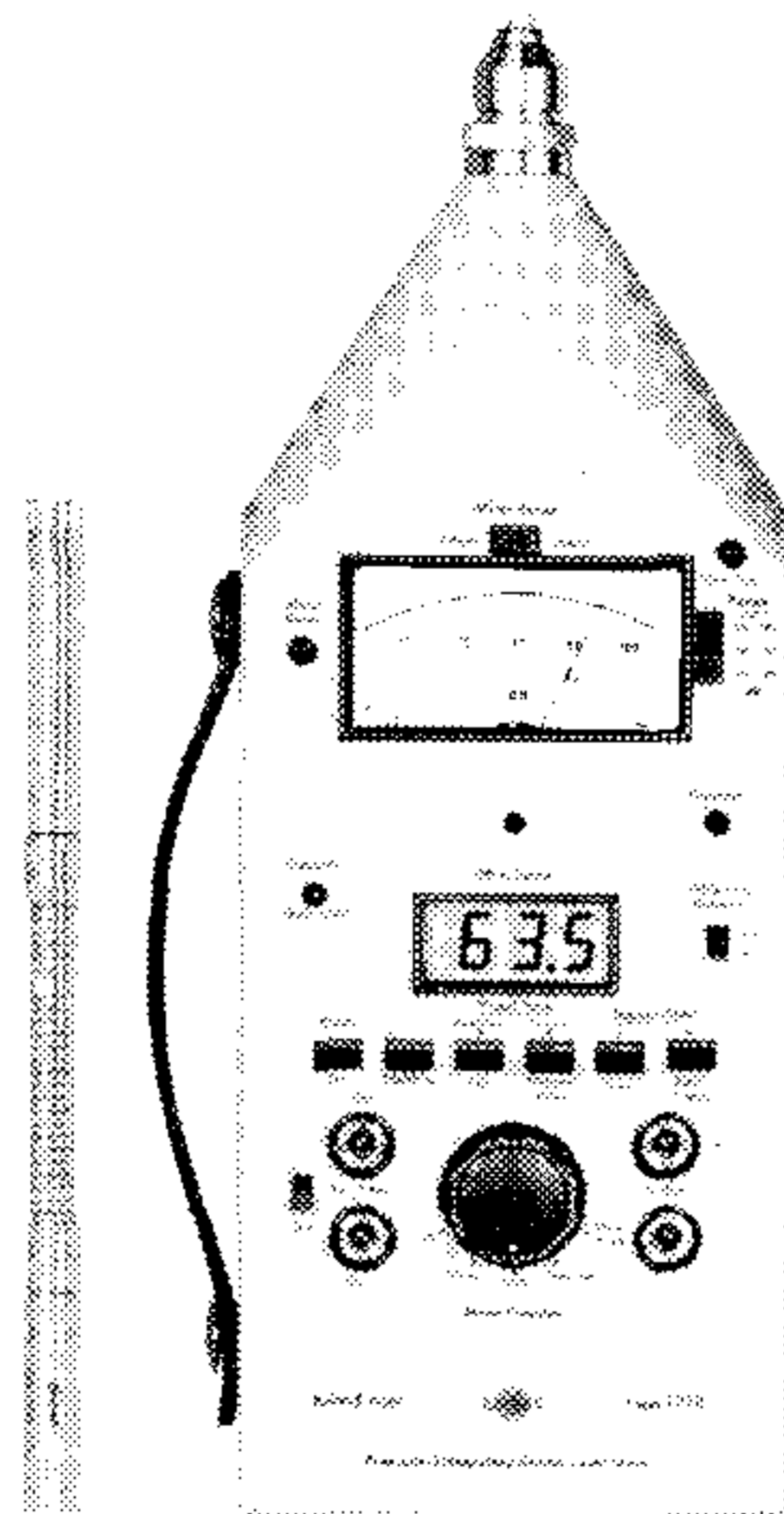

The features of the Precision Integrating Sound Level Meter Type 2218 are optimized for applications in the field of community noise, machine noise emission and occupational noise exposure. It is an L_{eq} meter with a digital display and a precision sound level meter with analog read-out combined in one compact, battery operated, portable unit. The L_{eq} is measured in accordance with ISO R1996 and 1999 and DIN 45641; the sound level meter complies with IEC 179 and 179A as well as DIN 45633 parts 1 and 2 and ANSI 1.4-1971 (Type 1 sound level meter) standards.

The L_{eq} value calculated is shown on a 3 1/2 digit liquid crystal display with a resolution of 0,1 dB. Alternatively, the elapsed time may also be displayed with a maximum resolution of 0,001 hour. The measuring period (maximum up to 10^5 seconds, 27,7 hours) can be preset so that the measurement is automatically stopped at the end of the period. The 2218 also has provision for measuring the Single Event Noise Exposure Level, L_{AX} used for describing single events such as flyovers.

The sound level meter is equipped with a high sensitivity 1/2" condenser microphone Type 4165 giving a measuring range from 25 dB to 145 dB. The measuring range setting is displayed in windows on the linear meter scale to facilitate reading.

The meter response of the instrument may be switched to the standardized "Fast", "Slow" and "Impulse" time constants as well as to indicate the absolute peak value of the measured signal.

Input and output sockets for connection to external filters are incorporated and two analog outputs (AC and DC) give the possibility for feeding the results to level recorders, tape recorders etc. (sound level only).

The 2218 is powered from 3 1,5 V alkaline batteries giving approximately 25 hours of continuous operation. As a very valuable feature a mercury battery is built in the instrument to protect the memory content of the L_{eq} meter in case of power failure or if the power batteries have to be changed during the measurement.

Wow and Flutter Meter Type 6203

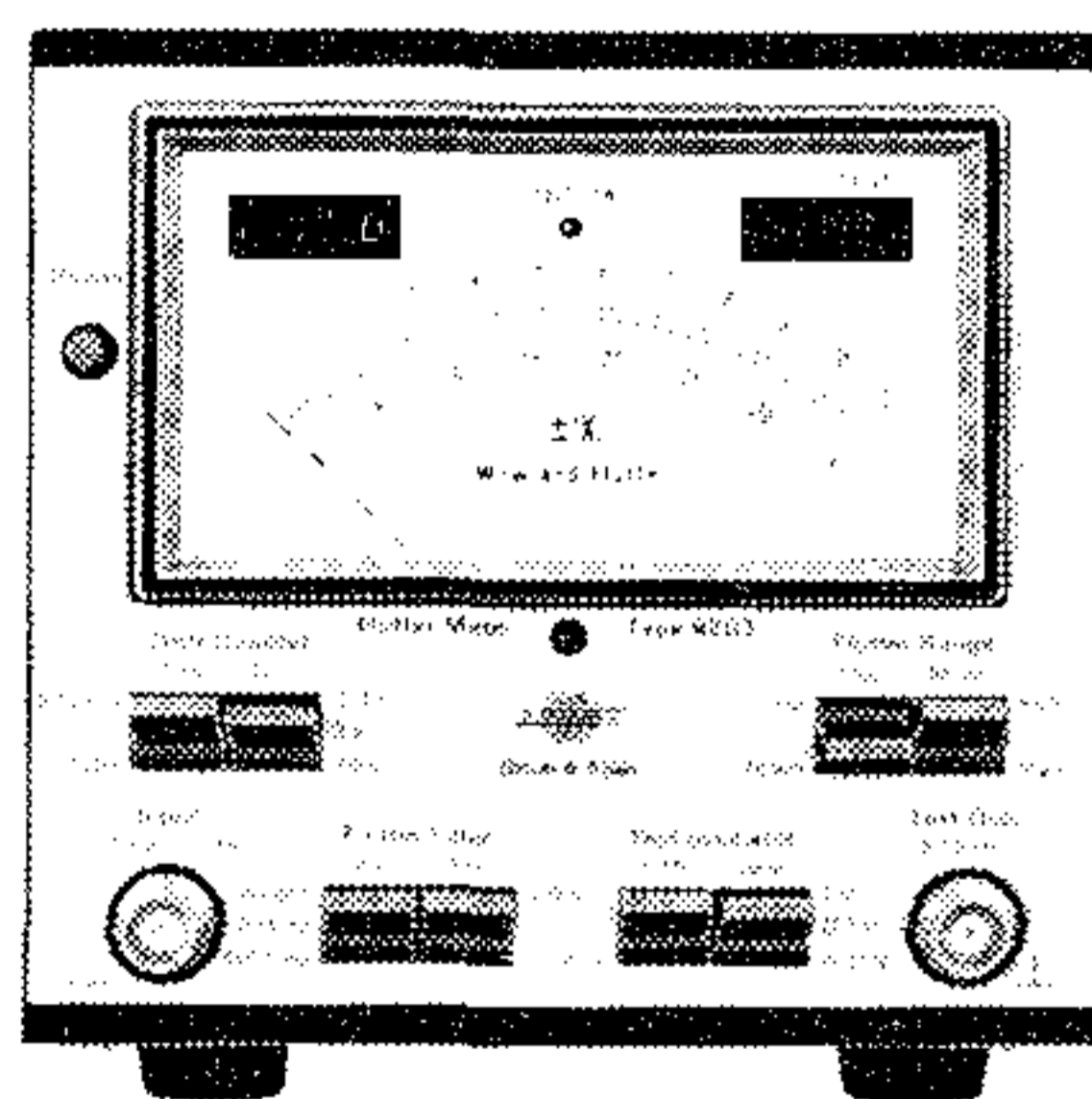

The Wow and Flutter Meter Type 6203 uses analog and digital techniques for automatic measurement of peak flutter and drift of sound recording and reproduction equipment.

Percentage drift from $\pm 0,01\%$ to $9,99\%$ relative to 3 or 3,15 kHz can be read off a 3-digit LED display while the percentage peak wow and flutter is indicated on an auto-ranging analogue meter. An ultra-stable quartz oscillator provides the standardized 3,15 kHz reference signal for recording purposes. Alternatively, for measurements on disc reproduction equipment, the B & K Test Record QR 2010 provides a 3,15 kHz test track.

The three prime features that facilitate the use of the instrument are:

- 1) its self tuning circuitry which automatically locks onto and follows the frequency of a drifting signal
- 2) its automatic selection of wow and flutter percentage measuring range with digital indication of the range selected (can also be chosen manually)
- 3) its automatic level ranging facility covering signals between 10 mV and 30 V.

The 6203 performs weighted quasi-peak wow and flutter measurements in accordance with DIN 45 507, IEC 386, CCIR 409 and IEEE 193. The weighting filter may also be switched out for linear measurements in the ranges 0,1 Hz to 315 Hz and 0,1 Hz to 1000 Hz. External filters may be connected to the 6203 for frequency analysis to identify the individual flutter components. The flutter signal is also available as a DC or AC output for XY or level recording purposes. Other features include overload indicators and a calibration check whereby a reference deflection of $\pm 1\%$ peak on the meter is produced.

Photo-Tacho Probe MM 0012

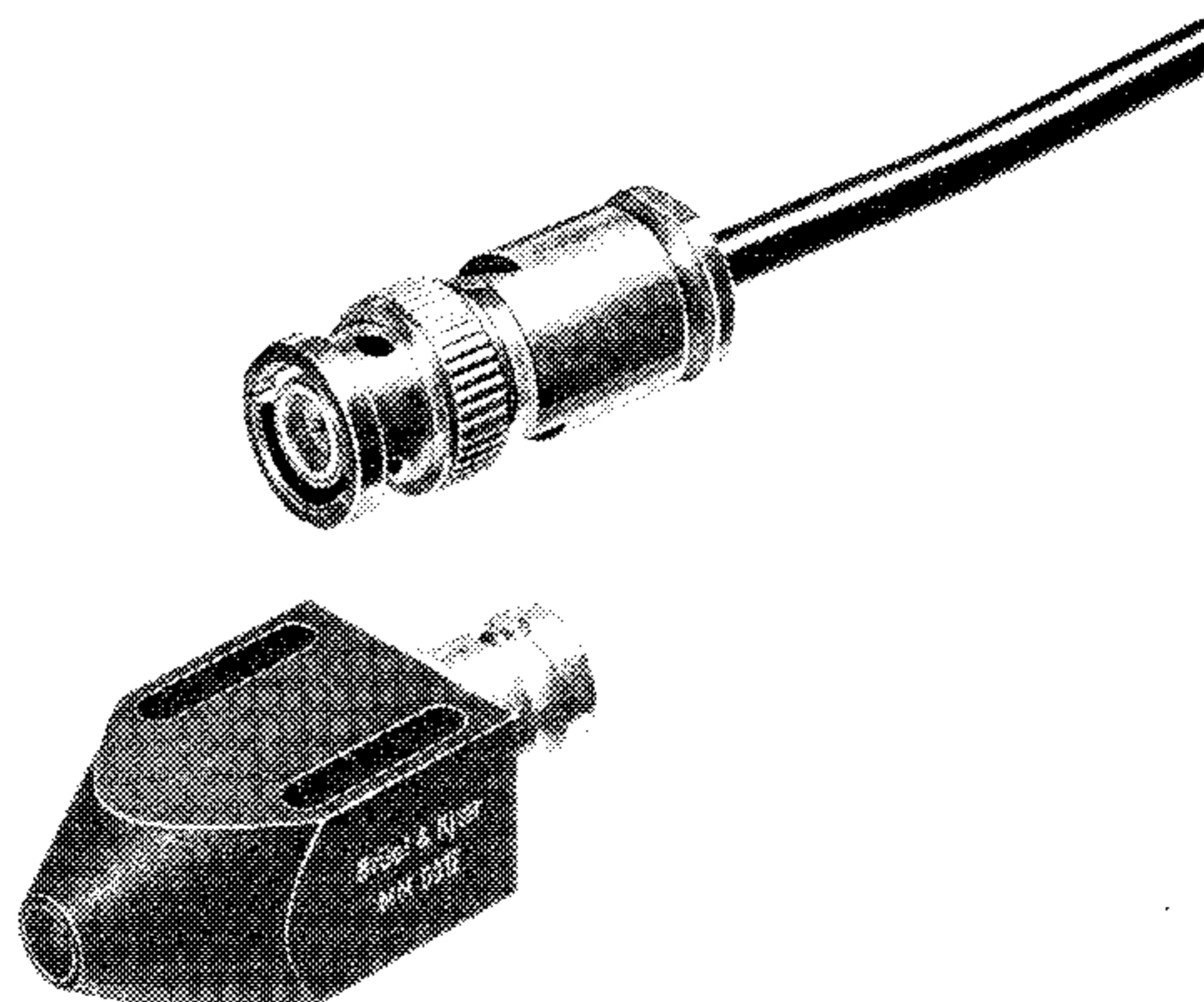

Photoelectric Tachometer Probe MM 0012 gives a well defined pulse output which is a function of the reflectivity of contrasting surfaces interrupting the beam of infra-red light projected by the probe. A prime application of the probe is to provide a trigger signal in synchronisation with rotating machine parts for tuning the Tracking Filter Type 1623 and the Waveform Retriever Type 6302. Projecting the beam from the probe at a piece of contrasting tape fixed to a rotating shaft at distances as great as 15 to 20 mm is sufficient to provide a signal amplitude of several tens of mV. The probe is powered from a 6 to 10V DC supply which is provided at the trigger input socket, when used with one of the aforementioned instruments.

PREVIOUSLY ISSUED NUMBERS OF BRÜEL & KJÆR TECHNICAL REVIEW

(Continued from cover page 2)

- 2-1974 On Signal/Noise Ratio of Tape Recorders.
On the Operating Performance of the Tape Recorder
Type 7003 in a Vibrating Environment.
- 1-1974 Measurements of averaging times of Level Recorders
Types 2305 and 2307.
A simple Equipment for direct Measurement of Reverberation
Time using Level Recorder Type 2305.
Influence of Sunbeams striking the Diaphragms of Measuring
Microphones.
- 4-1973 Laboratory tests of the Dynamic Performance
of a Turbocharger Rotor-Bearing System.
Measurements on the Resonance Frequencies of
a Turbocharger Rotor.
- 3-1973 Sources of Error in Noise Dose Measurements.
Infrasonic Measurements.
Determination of Resonance Frequencies of Blades and
Disc of a Compressor Impeller.

SPECIAL TECHNICAL LITERATURE

As shown on the back cover page Brüel & Kjær publish a variety of technical literature which can be obtained from your local B&K representative.

The following literature is presently available:

- Mechanical Vibration and Shock Measurements
(English, German, Russian)
- Acoustic Noise Measurements (English, Russian), 2. edition
- Strain Measurements
- Frequency Analysis (English)
- Electroacoustic Measurements
(English, German, French, Spanish)
- Catalogs (several languages)
- Product Data Sheets (English, German, French, Russian)

Furthermore, back copies of the Technical Review can be supplied as shown in the list above. Older issues may be obtained provided they are still in stock.

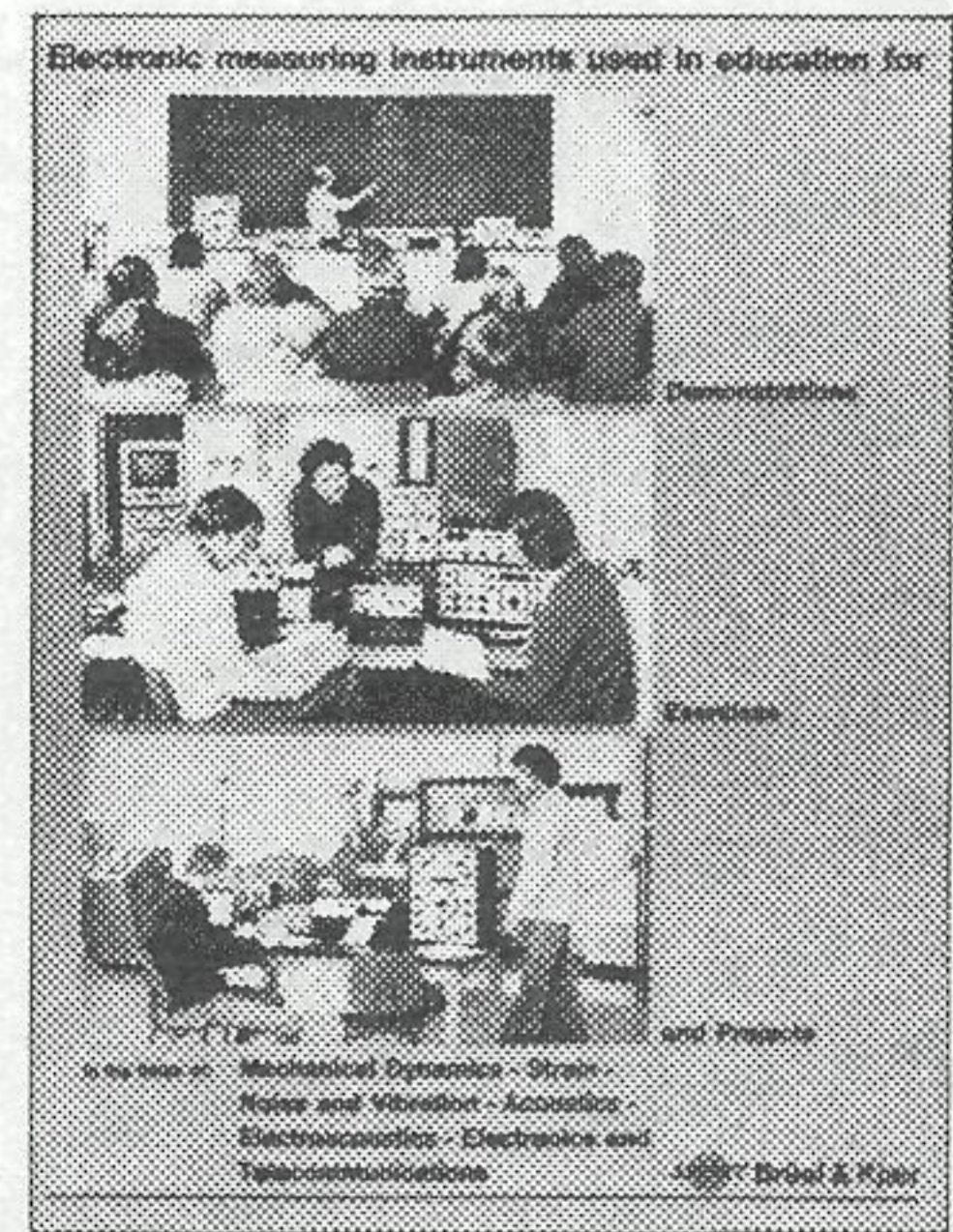
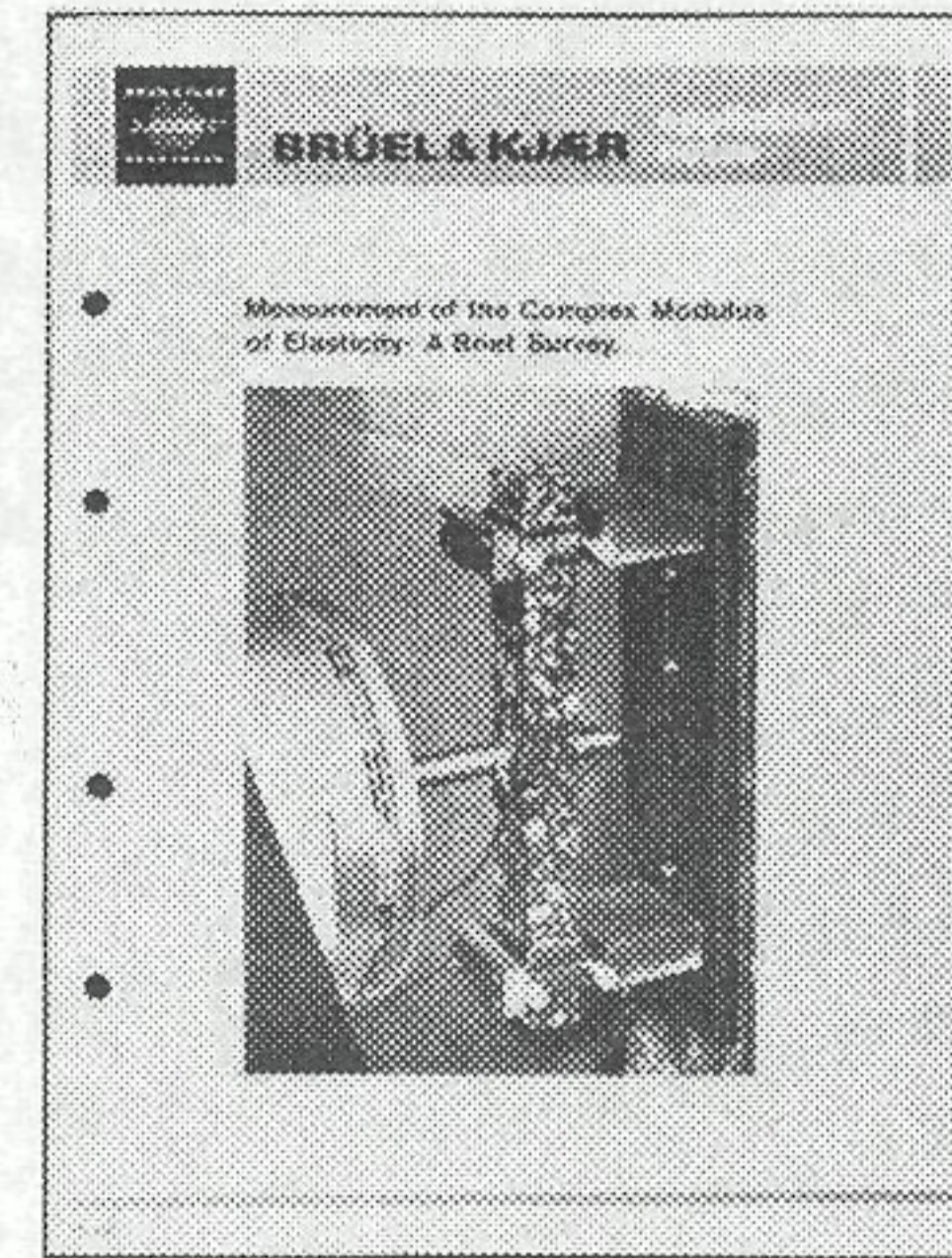
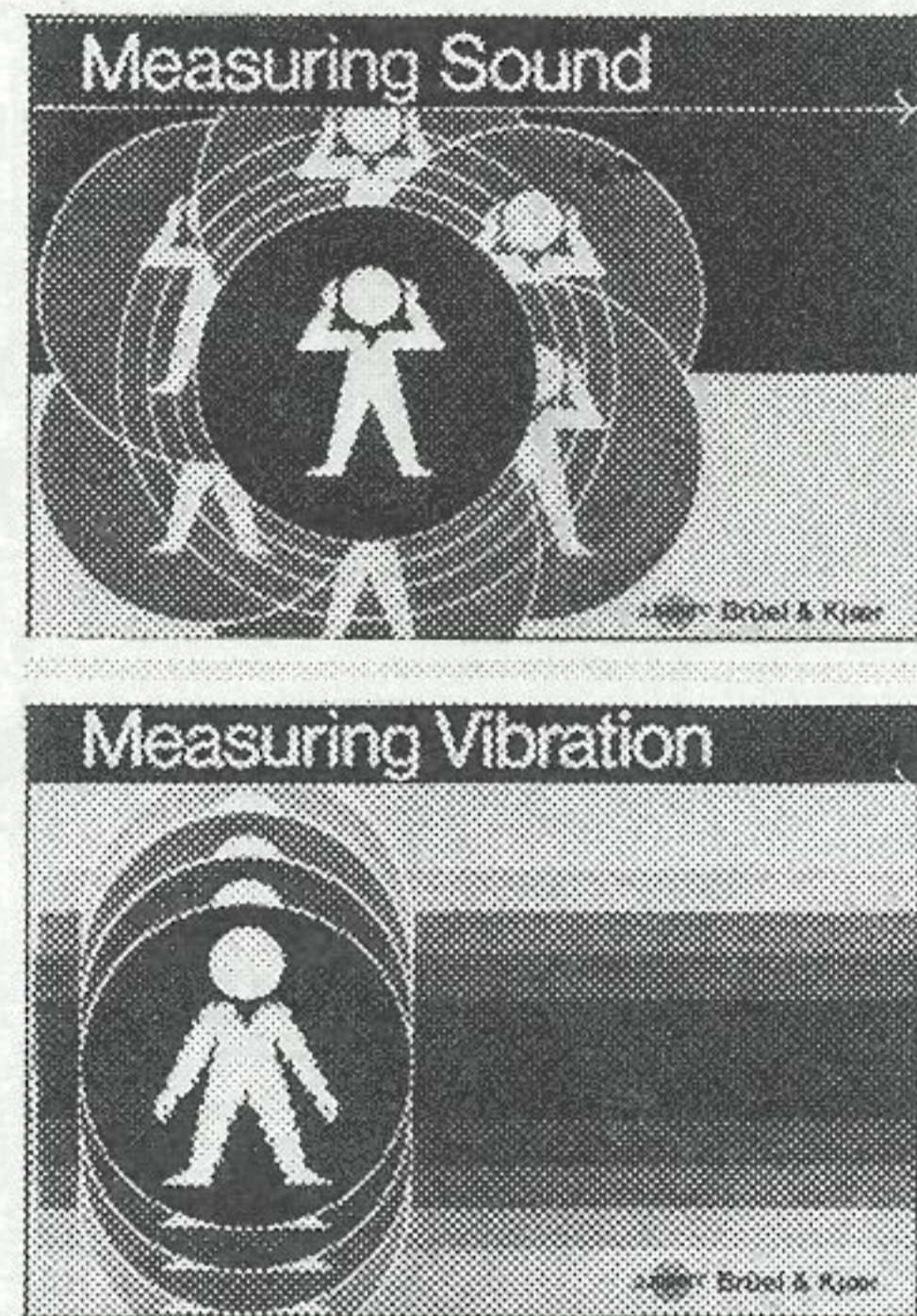
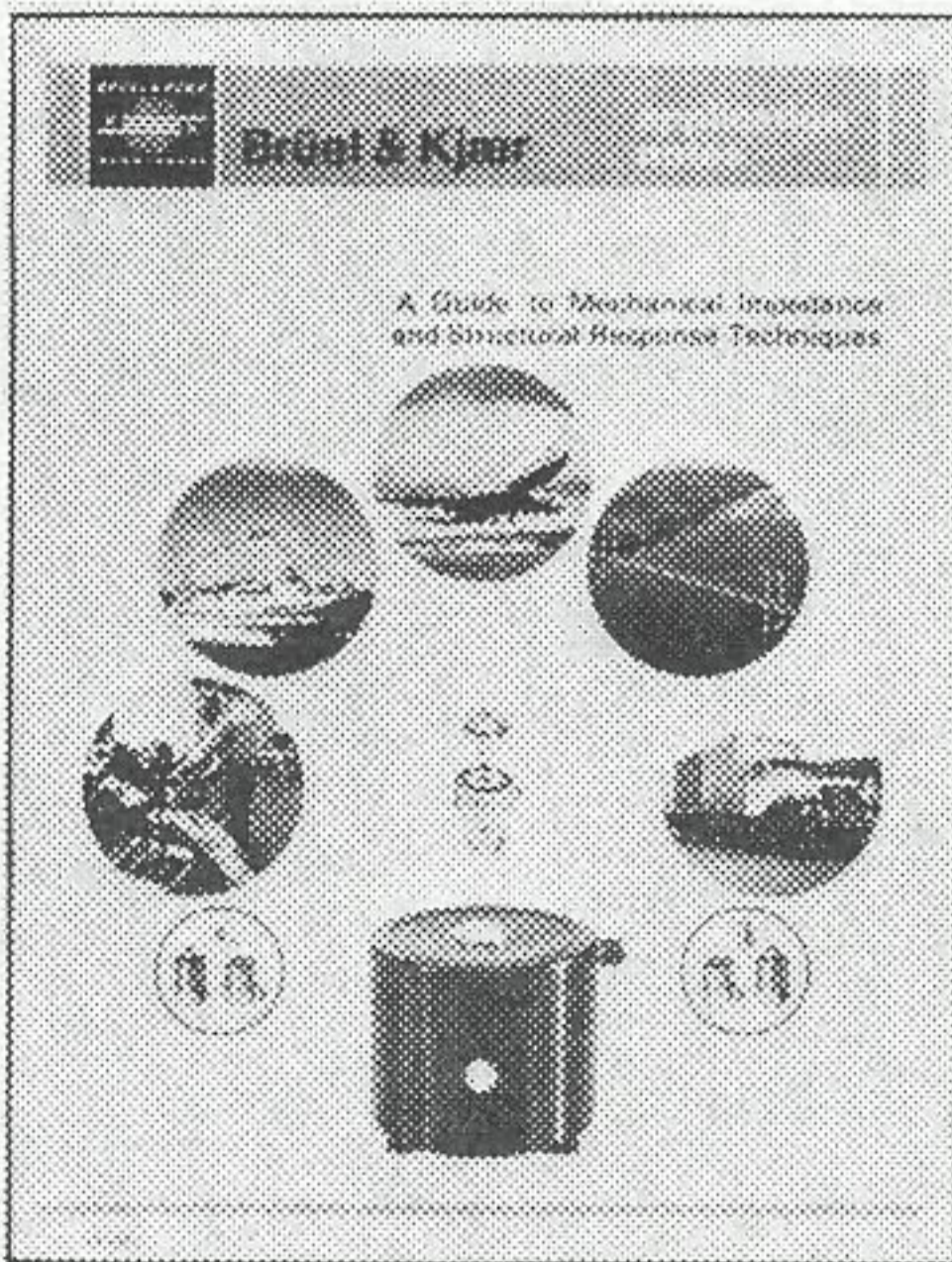
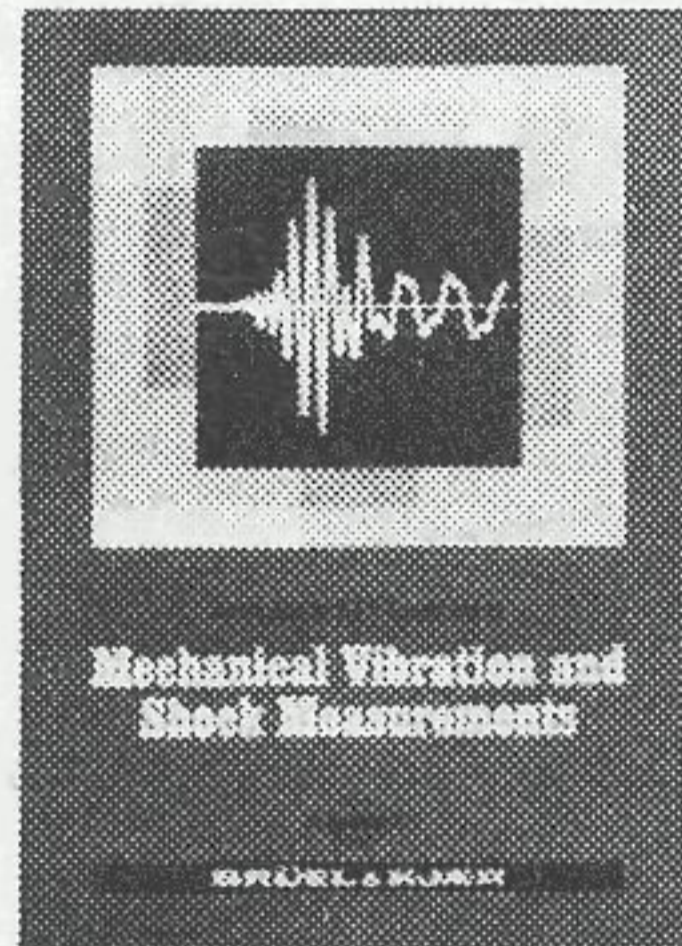
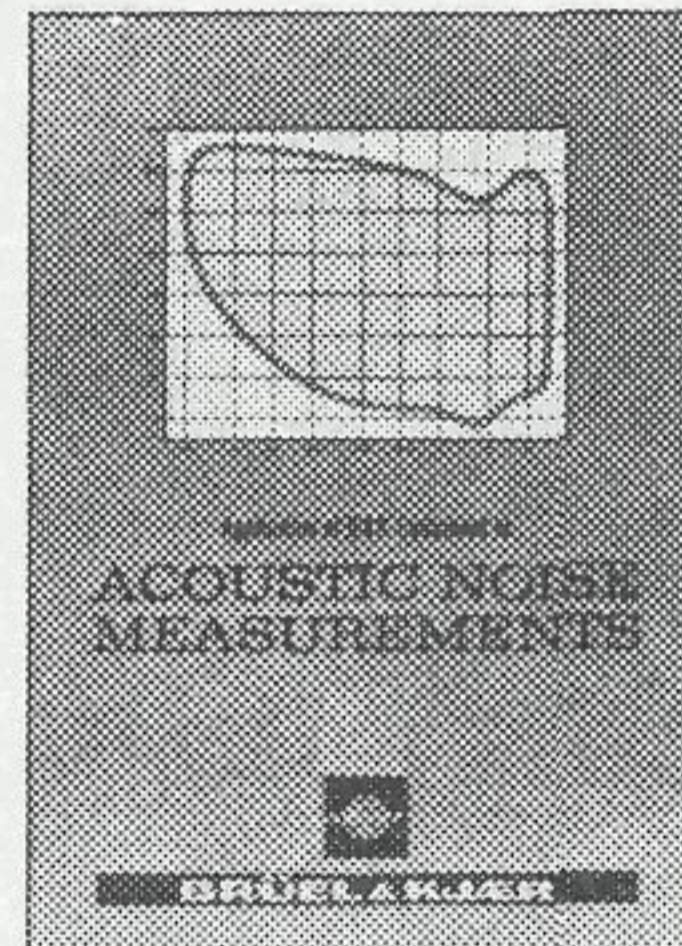
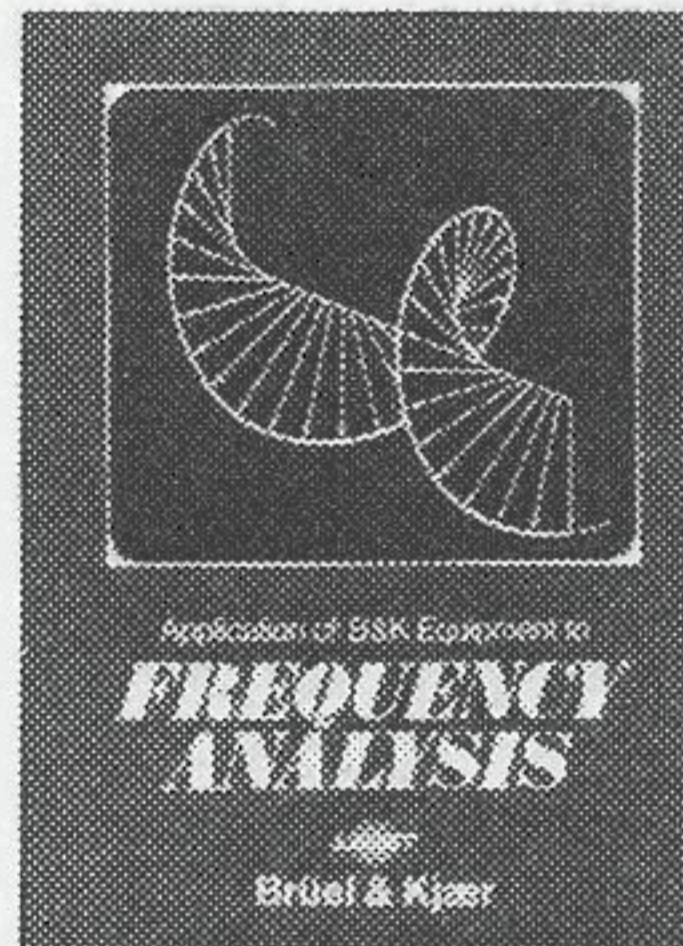
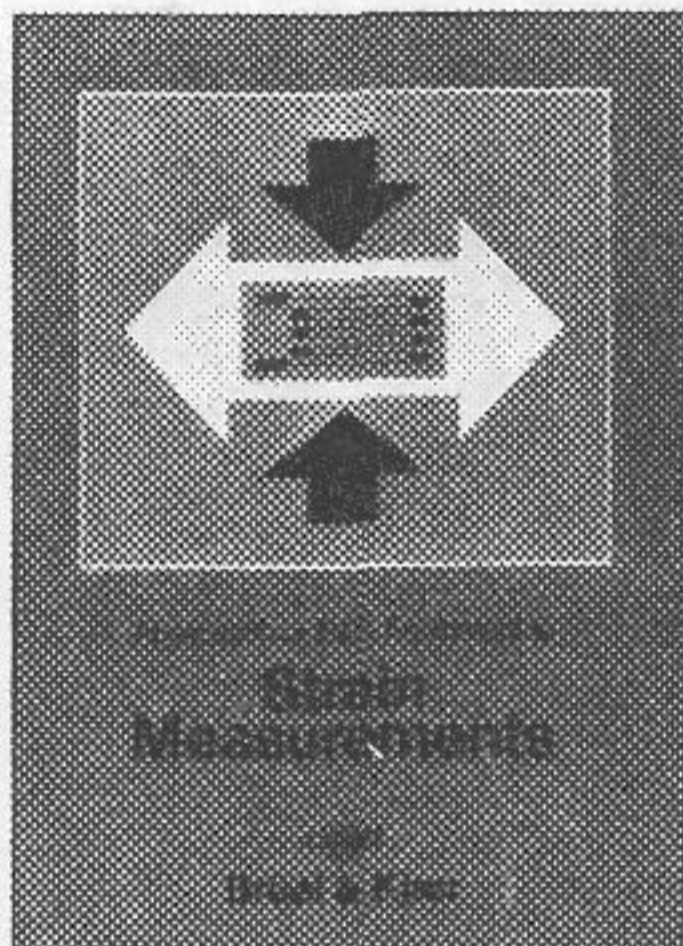
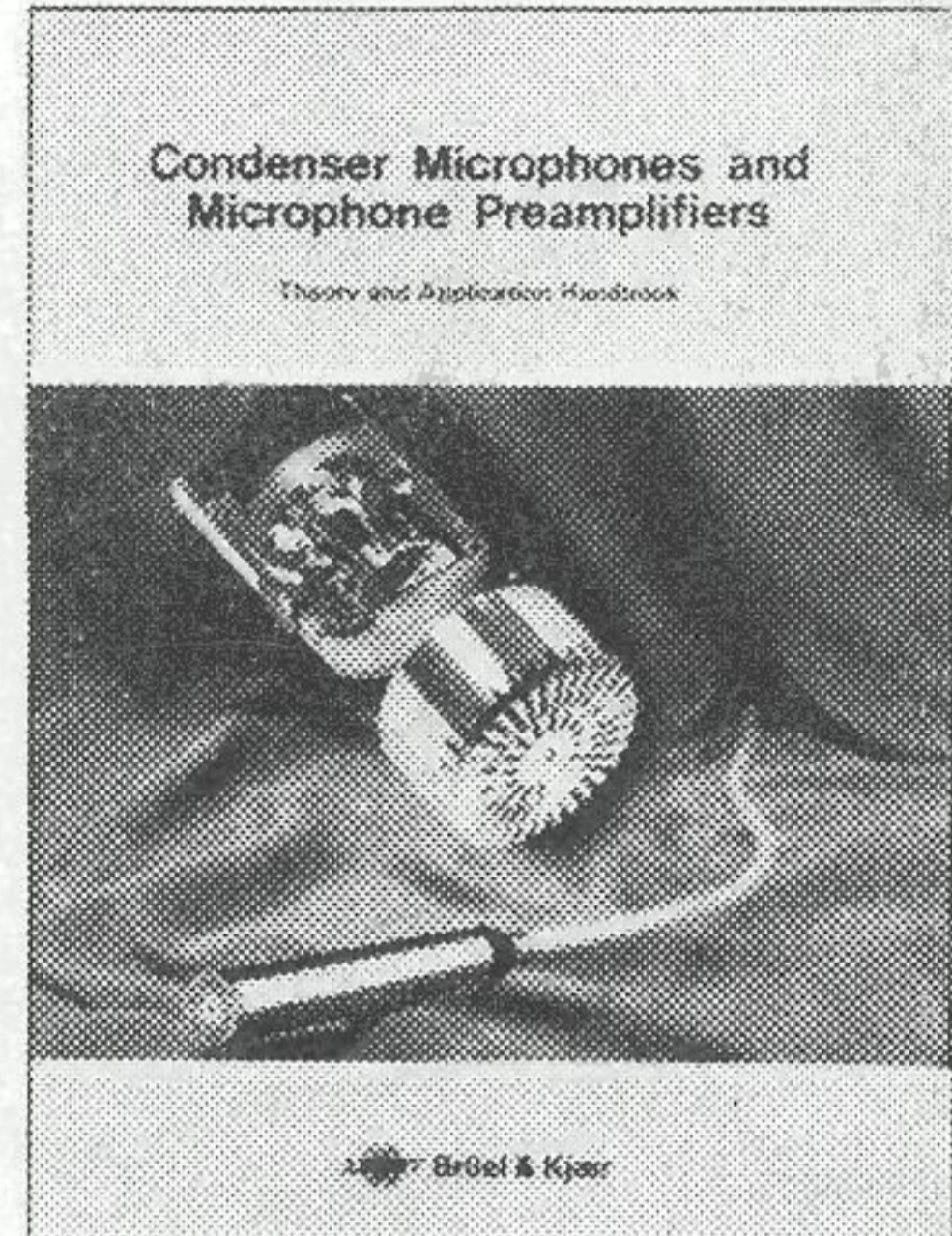
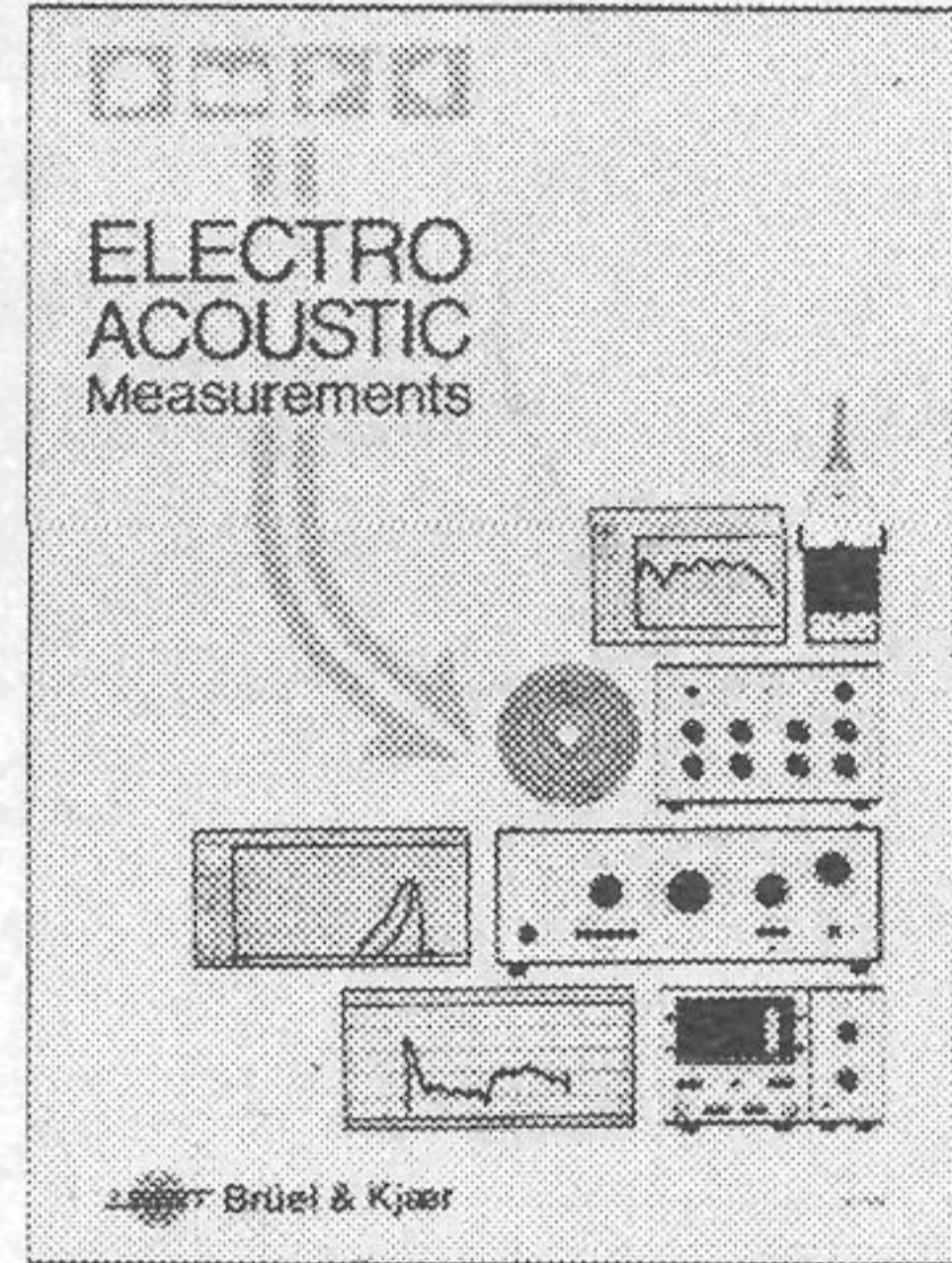
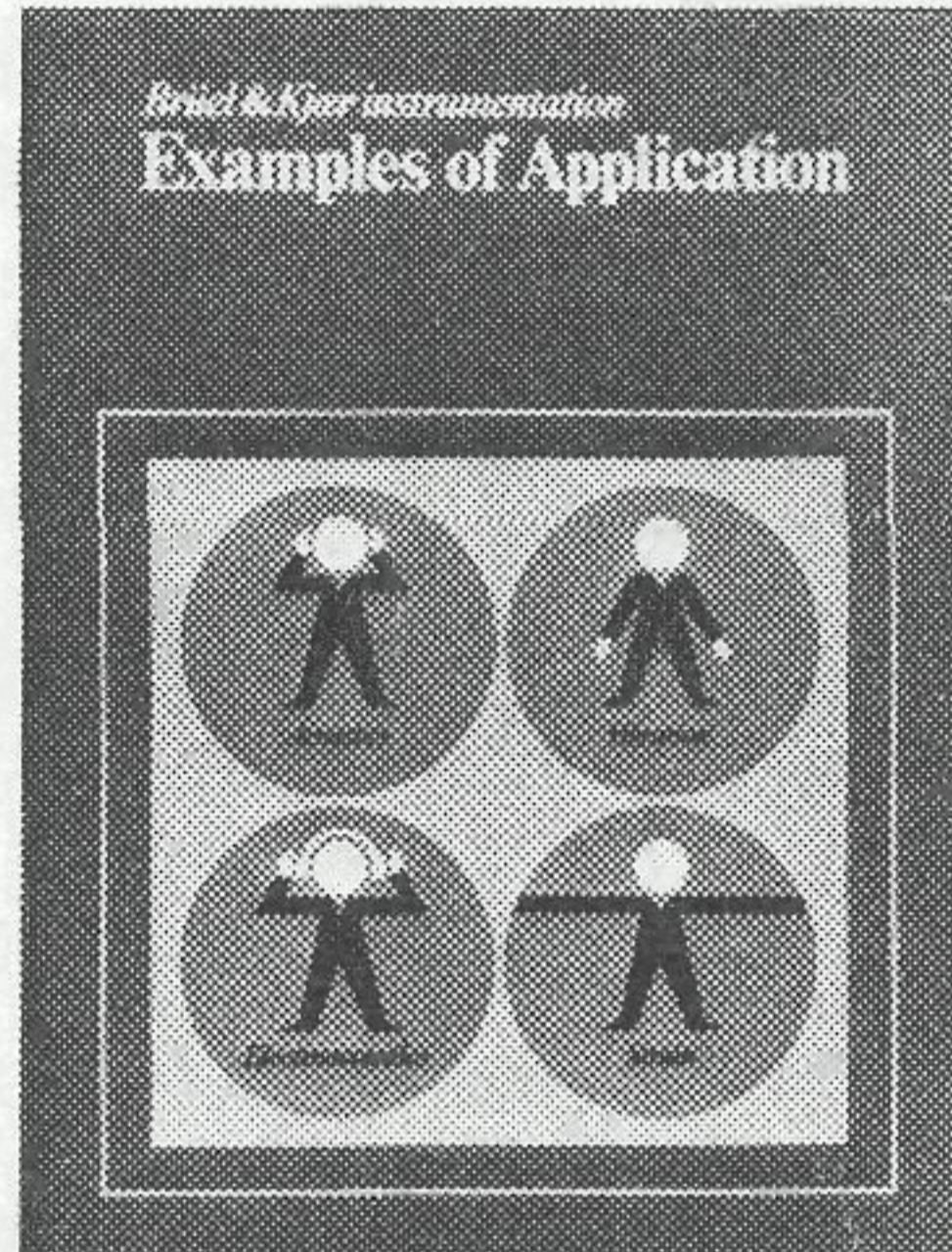
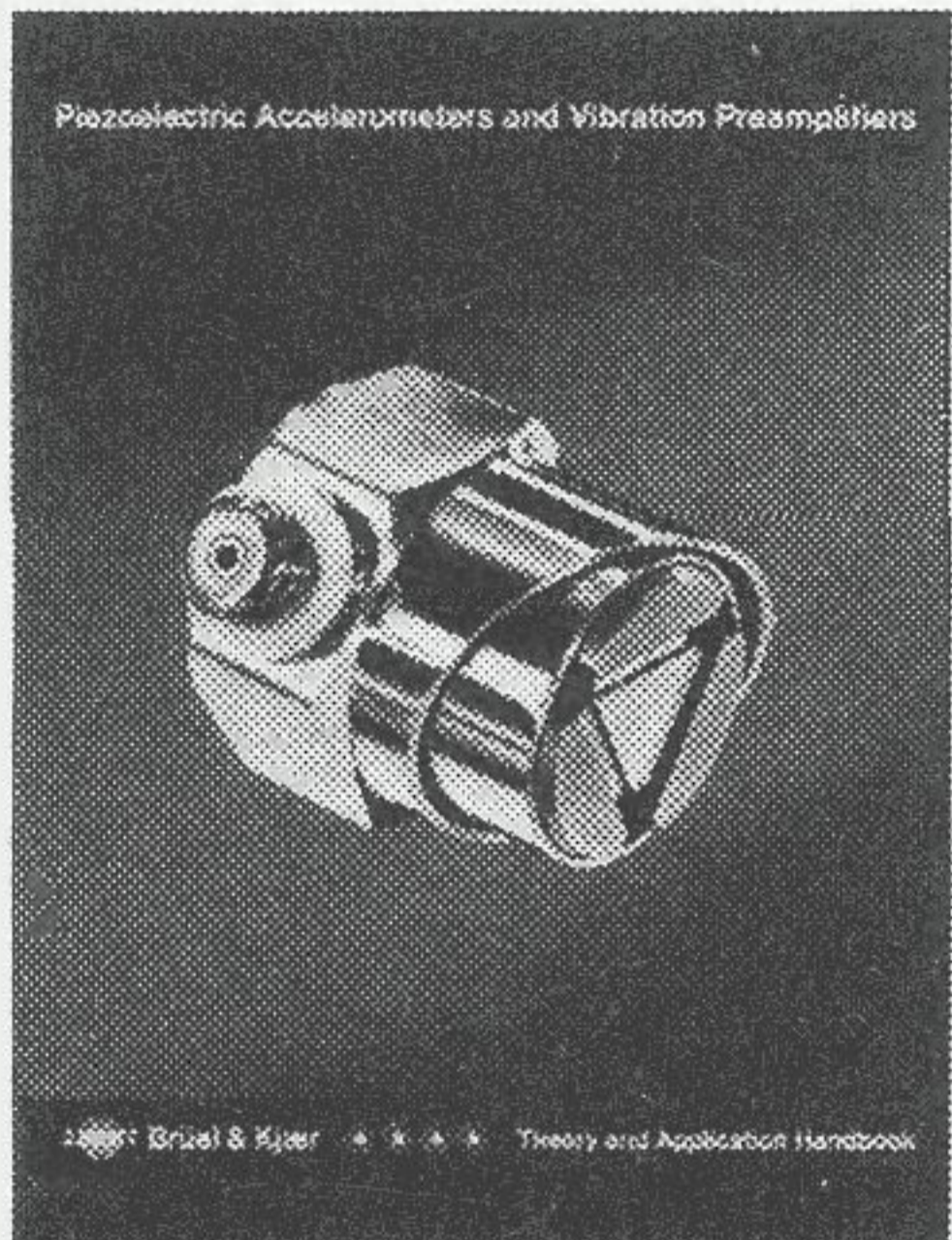

Brüel & Kjær

DK-2850 NÆRUM, DENMARK • Telephone: + 45 2 80 05 00 • Telex: 37316 bruka dk